



# QF30

**Diaphragm pump with plastic pump chamber  
Single use (SU)**

## Operation Manual

Original operation manual



1	General .....	3	3.7.1	Control panel HT .....	27
1.1	Manufacturer and Service .....	3	3.7.2	QControl .....	28
1.2	Exclusion of liability .....	3	3.8	Optional accessories .....	28
1.3	Presentation conventions .....	3	4	Assembly/installation .....	29
1.4	Pump unit.....	4	4.1	Transport and storage .....	29
1.5	Version history .....	4	4.2	Space requirement.....	30
1.6	Conformity .....	4	4.3	Connections .....	31
2	Safety.....	5	4.3.1	Pipes.....	31
2.1	Intended use .....	5	4.3.2	Electric cables .....	31
2.2	Prohibited use .....	5	4.3.3	Collection vessel .....	31
2.3	Warning notices .....	5	4.4	Parameter settings .....	31
2.4	Personnel requirements .....	5	5	Installation/removal .....	32
2.5	Residual risks.....	6	5.1	Assembling the pump chamber .....	33
2.5.1	Electric current.....	6	5.2	Disassembling the pump chamber .....	34
2.5.2	Harmful media.....	6	6	Commissioning.....	35
2.5.3	Pressure .....	6	6.1	Test run.....	35
2.5.4	Hot surfaces.....	7	7	Operation .....	36
2.5.5	Crushing and cutting .....	7	7.1	Safety.....	36
2.5.6	Noise .....	7	7.2	Switching on.....	36
3	Description .....	8	7.3	Shutdown .....	36
3.1	Technical data.....	8	7.4	Operation with the control panel HT .....	37
3.2	Sub-assemblies.....	12	7.4.1	Starting the pump unit .....	37
3.2.1	QF30-HT .....	12	7.4.2	Stopping the pump unit .....	38
3.2.2	QF30-QCON .....	13	7.4.3	Switching off the pump unit .....	38
3.2.3	QF30-QCON-EP/-E/-P .....	14	7.4.4	Setting the speed .....	38
3.2.4	Ring drive PQ30A-X01 .....	15	8	Maintenance.....	39
3.2.5	Pump chamber QF30DM .....	17	8.1	Safety.....	39
3.2.6	Base plate PQ15E-HT.....	19	8.2	Maintenance intervals .....	40
3.2.7	Base plate PQ15E-HT.....	20	8.3	Replacing the WLC unit.....	41
3.2.8	Drive unit PQ15G-HT-NT .....	21	8.4	Cleaning.....	44
3.2.9	Motor flange PQ5T-HT .....	22	8.4.1	Gamma radiation.....	44
3.2.10	Pump conveying chamber PQ30W .....	23	9	Malfunctions .....	45
3.3	Motor.....	24	9.1	Elimination of faults .....	45
3.4	Performance chart.....	24	9.2	Return .....	47
3.5	Water-like fluids.....	25	10	Disposal .....	48
3.6	Labelling .....	25	11	Glossary .....	49
3.6.1	Pump unit type label.....	26			
3.7	Control units.....	27			

## 1 General

Read this operating manual carefully before putting the pump or the pump unit into operation. Always follow the instructions contained in this operating manual. Keep the operating manual close at hand in the vicinity of the pump.

PSG Germany GmbH also manufactures pumps and pump units according to specific customer requirements and adapted to special applications. The descriptions in this operating manual can differ from your actual pump.

Also observe the operating manuals for the motor and other installed components or optional accessories.

### 1.1 Manufacturer and Service

PSG Germany GmbH  
Hochstraße 150-152  
47228 Duisburg, Germany  
Telefon: +49 2065 89205-0  
E-mail: [info@cpc-bio.com](mailto:info@cpc-bio.com)  
Internet: [www.cpc-bio.com](http://www.cpc-bio.com)

### 1.2 Exclusion of liability

All warranty rights will be void in case of incorrect operation or misuse, failure to observe the operation manual, in particular the safety notes, as well as unauthorised modification of the pump unit or installation of non-genuine spare parts. The manufacturer will accept no liability for damages and consequential damages resulting from this.

Quattroflow is a trade name of PSG Germany GmbH.

PSG Germany GmbH endeavours to continuously improve the product and reserves the right to make modifications to the technology and/or design without prior notice.

### 1.3 Presentation conventions

This operating manual uses the following presentation conventions:

Running text contains descriptions and explanations.

- First level bulleted lists are preceded by dots and list elements.
  - Second level bulleted lists are preceded by circles and list elements belong to a first-level element.
- ▶ Handling instructions are indicated by an arrow and guide your actions.

Handling instructions are listed in the order in which they are performed.

**⚠ WARNING NOTICES** – Warning notices warn against dangers and give handling instructions to avoid the danger. (Further information can be found in chapter Warning notices on page 5.).

The manual uses the term pump for the pump body and the term pump unit for the entire functional unit motor with coupling and pump body.

## 1.4 Pump unit

This manual applies for the following pump units:

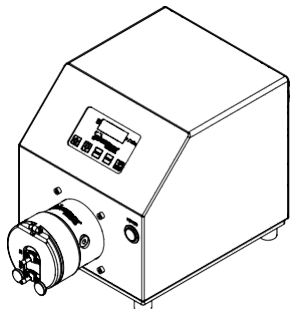

### Pump unit QF30-HT

- Integrated control panel HT
- Drive: BLDC 135W
- Speed control: Control panel
- Eccentric shaft: 3°
- Flow rate: 0.06 - 30 l/h

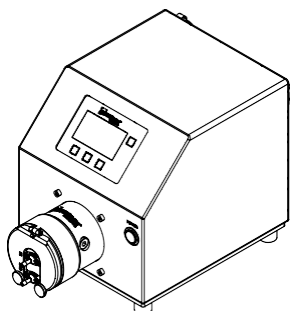

### Pump unit QF30QCON

- Integrated control panel QCON
- Drive: BLDC 135W
- Speed control: Control panel
- Eccentric shaft: 3°
- Flow rate: 0.06 - 30 l/h

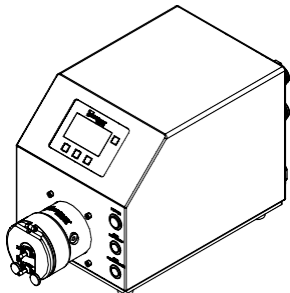

### Pump units QF30QCON-EP / QCON-E / QCON-P

- Integrated control panel QCON with integrated flow and pressure measurement
- Drive: BLDC 135W
- Speed control: Control panel
- Eccentric shaft: 3°
- Flow rate: 0.06 - 30 l/h

## 1.5 Version history

### Edition

2024-05

### Contents and revisions

- first edition

## 1.6 Conformity

The following EU regulations apply to the device:

- 2011/65/EU
- 2006/42/EC
- 2014/30/EU

## 2 Safety

This chapter contains important information for safe operation as well as safe installation and maintenance of the pump unit.

### 2.1 Intended use

- Pumping water-like fluids for industrial applications in batch mode.
- For indoor use only.

#### Typical applications:

- in filtration technology:
  - as a recirculation pump in tangential flow filtration systems (e.g. diaphragm cassettes, hollow fibre and spiral wound modules, ceramic elements)
  - as a feed pump through filter cartridges or sheet filters, virus and sterile filtration.
- in chromatography:
  - as a feed and/or dosing pump (e.g. gradient mixing)
  - as a feed pump for expanded-bed chromatography
- as a dosing pump
- as a feed pump in filling systems for small quantities

### 2.2 Prohibited use

- Pumping of unsuitable media or fluids, especially media which attack the diaphragm or other parts of the pump. If in doubt, consult the Material and Certification Guide or contact the Service Department.
- Operation outdoors and in private households
- Operation in in-vitro diagnostics
- Operation in explosion-protected areas
- Operation with fluids for the food sector

### 2.3 Warning notices

These warning notices warn against dangers. Heed the warning notices to avoid dangers.

- ⚠ DANGER** – Danger of fatal or severe injuries.
- ⚠ WARNING** – Warning against possibly fatal or severe injuries.
- ⚠ CAUTION** – Beware of minor injuries.
- ATTENTION** – Property damages.
- NOTE** – General information and advice

### 2.4 Personnel requirements

The person must have the relevant skills for the kind of work to be performed.

Persons who work with the pump unit must meet these requirements:

- Competent planning and execution of processes according to the pumped fluid
- Competent use of instrumental-analytical work methods according to the pumped fluid
- Competent handling of the pumped fluid

Persons who service the pump or the pump unit must meet these requirements:

- Competent assembly and disassembly of mechanical, electrical and electronic components.
- Understanding of the interaction and assembly of the components.

The owner must ensure that all the information in this operating manual is fully available to all persons who work with the pump unit at all times.

## 2.5 Residual risks

Observe the valid rules for the protection of accidents and protection measures.

### 2.5.1 Electric current

Touching electrical components can cause fatal electric shock.

- ▶ Disconnect the pump unit from the power supply before working on it.
  - Pull out the mains plug.
  - Disconnect all phases of the pump unit from the mains.
- ▶ Never open the motor housing or control panel and do not change any electrical components in the pump unit.
- ▶ Ensure that all cables are undamaged.

### 2.5.2 Harmful media

The pump can deliver fluids that are toxic, caustic, aggressive or otherwise harmful to persons or hazardous to the environment. Strong and hot alkaline solutions are sometimes used for cleaning (CIP, SIP). There is a risk of serious damage to health by contact.

- ▶ Observe the safety data sheet for the fluid used and wear the protective equipment or take the protective measures specified in the data sheet.
- ▶ Make preparations for possible leakages. When working on the pump, always behave as if there were fluid in the pump.
- ▶ Avoid chemical and biological reactions in the pump (mixing of different substances).
- ▶ Avoid freezing the fluid.
- ▶ Avoid contact of corrosive fluids (e.g. NaCl, HCl) with the outer stainless steel surfaces of the pump (e.g. shroud, base plate).

### 2.5.3 Pressure

The pump can be operated up to a maximum permissible pumping pressure. The maximum permissible pumping pressure depends on the temperature of the fluid. The values for the maximum permissible pumping pressure are specified in the chapter Technical data, page 8, and on the pump unit.

On exceeding the maximum permissible pressure, the diaphragm can tear and fluid can spill and injure persons.

- ▶ Always comply with the maximum permissible pumping pressure or use an overpressure protection device.
- ▶ Make sure that the suction and pressure lines are adequately dimensioned and fastened.
- ▶ Only apply pressure to the pump chamber when the pump chamber is mounted on the drive.

#### 2.5.4 Hot surfaces

The pump can carry hot fluids. These can heat up parts of the pump unit and the lines (>72°C). There is a risk of burns when touching.

- ▶ Do not touch the pump when the pump unit is in operation.
- ▶ Allow hot parts to cool down.
- ▶ Keep the air vents and filter clear. Ensure that the heat can escape.

#### 2.5.5 Crushing and cutting

The eccentric shaft rotates in a housing (ring drive). There is a risk of crushing fingers in the space in between.

- ▶ Only operate the pump with the pump chamber mounted.
- ▶ Disconnect the pump unit from the power supply before working on it.

There is a danger of being cut by sharp edges and corners and crushed by falling, heavy parts during maintenance and assembly.

- ▶ Wear cut-proof protective gloves for maintenance and assembly work.
- ▶ Wear safety gloves.

#### 2.5.6 Noise

The pump unit can contribute to noise pollution (<80 dB).

- ▶ It is recommended to wear suitable hearing protection.

### 3 Description

The pump unit is a machine for delivering fluids which is particularly insensitive to continuous stress and contamination in the fluid. Designed as a piston diaphragm pump, the pump delivers the fluid in self-enclosed volumes.

The diaphragm consists of 4 segments. A connecting ring that is moved back and forth from its centre position by an eccentric shaft activates the segments and creates the stroke movement. An electric motor drives the eccentric shaft. The stroke length is determined by the angle of the eccentric shaft.

The motor speed determines the pump performance. The direction of flow of the pump is independent of the direction of rotation of the motor.

The pump is self-priming and dry run-protected. There are no rotating parts in the pump chamber that can rub against each other. As a displacement pump, the pump already builds up the required pressure at low speeds.

The plastic pump chamber in contact with the product is intended for single use (single-use applications) and can be easily replaced. This feature of the pump eliminates the need for cleaning and, if necessary, cleaning validation of the pump. Furthermore, cross-contamination (product carry-over) can be ruled out.

**NOTE** – The direction of flow of the pump can be adjusted by turning the pump chamber. The direction of flow can be seen from the "IN" and "OUT" labels on the connecting nozzles or the pressure plate.

#### 3.1 Technical data

The technical data refer to the standard version of the pump.

**Special pump versions (e.g. special connectors) may have different data.**

The following connection cable variants are supplied for all versions:

- PQ12P-HT-E = EU
- PQ12P-HT-A = America
- PQ12P-HT-U = UK

Please also refer to the detailed documentation supplied.

Description	Unit	QF30-HT	QF30-QCON	QF30-QCON-EP/-E/-P
Delivery rate eccentric shaft 3°:				
max.	lph		30	
min.	lph		0.06	
Pressure according to temperature of fluid:				
<40°C	bar		4	
> 40°C	bar		4	
Minimum vacuum pressure at the pump inlet:				
Pumped fluid (eccentric shaft 3°)	bar		-0.3	

Description	Unit	QF30-HT	QF30-QCON	QF30-QCON-EP/-E/-P
Maximum temperatures:				
Pumped fluid	°C		> 40 60 (short-term)	
Autoclave	°C		125	
Gamma (SU)	kGy		50	
Suction lift dry at optimum speed (3000 rpm):				
Eccentric shaft 3°	ml		1	
Volume data:				
Approximated volume per revolution at free output	ml		0.57	
Filling volume without connections	ml		5.2	
Residual volume (after idle with high-speed motor)	ml		<1	
Product-wetted surface (approx.):				
Surface area	cm <sup>2</sup>		70	
EPDM inlet and outlet valves	cm <sup>2</sup>		13.64	
EPDM O-rings and seals	cm <sup>2</sup>		1.19	
TPE diaphragms	cm <sup>2</sup>		6.95	
PP housing parts	cm <sup>2</sup>		47.58	
Product wetted materials (standard):				
Pump housing			PP	
Valve plate			PP	
Diaphragms			Santoprene	
Valves			EPDM	
O-rings			EPDM	
Non-product wetted materials (standard):				
Diaphragm housing lid			PP	
Bearing housing			1.4404	
base plate			1.4301	
Shroud			1.4301	
Pump speed range	rpm		1-1000	

Description	Unit	QF30-HT	QF30-QCON	QF30-QCON-EP/-E/-P
Connection specification (standard):				
Connection	"	1/8" (HoseBarb)		
Inside diameter	mm	2.5		
Position of connectors		Front		
Number of directions of flow		3		
Drive shaft diameter	mm	7		
Pump unit dimensions with motor and housing:				
Length [L]	mm	342	347	407
Width [W]	mm	200	200	200
Height [H]	mm	217	217	231
Pump unit weight	kg	8.7	9.1	Q-EP 12.7
				Q-P 12.3
				Q-E 12
IP protection class (whole pump)	IP	54		
Customs tariff number		84138100		
Temperature:				
Operation	°C	10 to 30		
Transport	°C	0 to 40		
Storage	°C	0 to 40		
Humidity	%	5-70% (non-condensing)		
Motor/gear:				
Manufacturer (standard)		Nanotec		
Type		PD4-CB59M024035-E-01		
Rated speed	rpm	1000		
Voltage	V	24		
Rated current	A	8		
Power	W	135		
Shaft diameter	mm	8		
IP protection class	IP	20		
Colour	RAL	9005 (black)		
Clutch		Claw coupling KTR (Rotex)		

Description	Unit	QF30-HT	QF30-QCON	QF30-QCON-EP/-E/-P
Noise:				
L <sub>pA</sub> (Pressure)	dB		65,7	
L <sub>WA</sub> (Power)	dB		77,9	
L <sub>PA</sub> (K1)	dB		4,0	
L <sub>WA</sub> (K1)	dB		16,3	
Control unit:				
Type		Control integrated into the housing		
Rated voltage	V	100-264		
Rated power	W	250		
Rated frequency	Hz	50-60		
Rated current	A	3.2 / 1.3		
Net shape		TN-S		
Mains supply		1L+N+PE		
Fuse		B10A		
Length, cross-section power cable	m; mm <sup>2</sup>	3; 3x2.08 / 3, 3x1		
Connection		NEMA 5-15 (US)		
		Three-pin plug (EU)		
		BS1363 (UK)		
Analogue input		4-20 mA	0-10 V, 4-20 mA	
Modbus interface		/	RS485	
Certificates/proofs (optional):				
Elastomers (product wetted)		USP <87>, <88> Cl. VI; FDA21CFR177; BSE/TSE Safe		
Stainless steel parts (product wetted)		3.1; surface roughness; ferrite (EN10204)		

### 3.2 Sub-assemblies

#### 3.2.1 QF30-HT

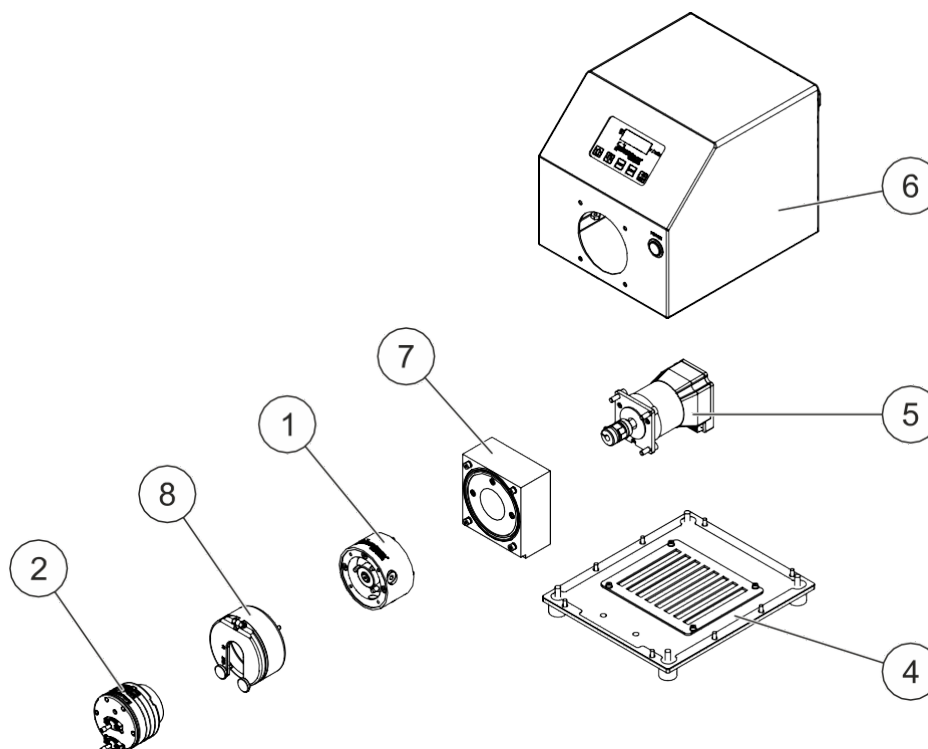

Fig. 1: Sub-assemblies QF30-HT

Item	Quantity	Designation	
1	1	PQ30A-X01	Ring drive for QF30SU, without motor flange
2	1	QF30DM	Quattroflow QF30SU single-use pump chamber made of PP with 1/8" hose connection
4	1	PQ15E-HT	Base plate HT and QCON, QF150
5	1	PQ15G-HT-NT	Drive unit Nanotec motor
6	1	PQ15N-HT-NT	Housing QF150HT
7	1	PQ15T-HT-NT	Motor flange for Nanotec
8	1	PQ30W	Feed chamber holder for QF30SU

3.2.2 QF30-QCON

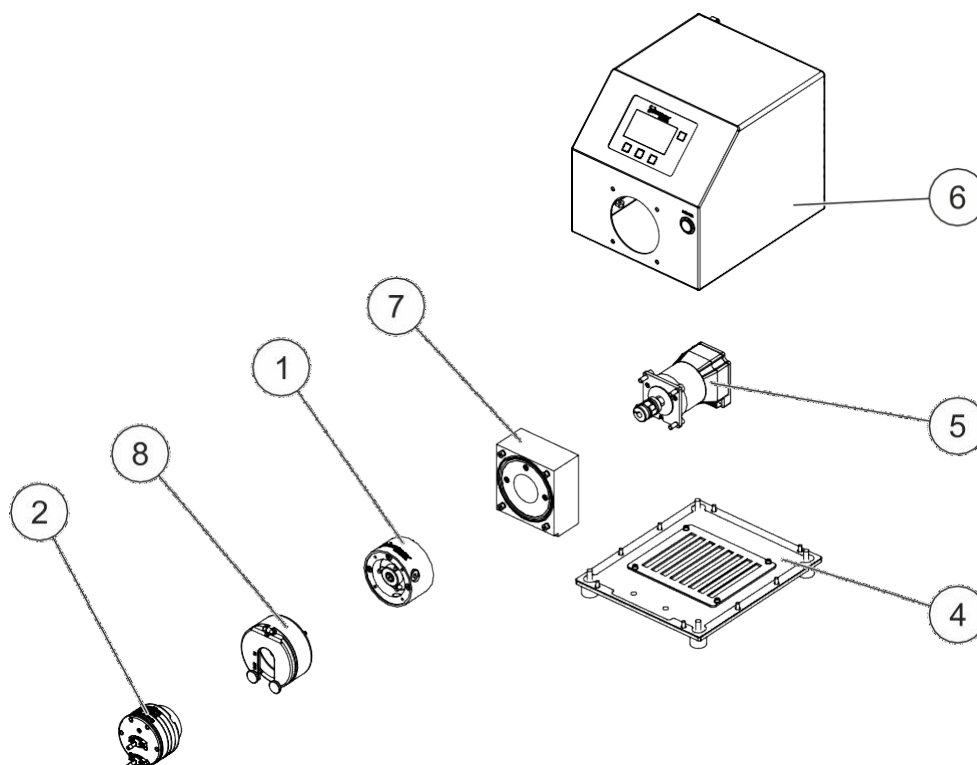

Fig. 2: Sub-assemblies QF30-QCON

Item	Quantity	Designation	
1	1	PQ30A-X01	Ring drive for QF30SU, without motor flange
2	1	QF30DM	Quattroflow QF30SU single-use pump chamber made of PP with 1/8" hose connection
4	1	PQ15E-HT	Base plate HT and QCON, QF150
5	1	PQ15G-HT-NT	Drive unit Nanotec motor
6	1	PQ15N-QCON-NT	Housing QF150QCON
7	1	PQ15T-HT-NT	Motor flange for Nanotec
8	1	PQ30W	Feed chamber holder for QF30SU

3.2.3 QF30-QCON-EP/-E/-P

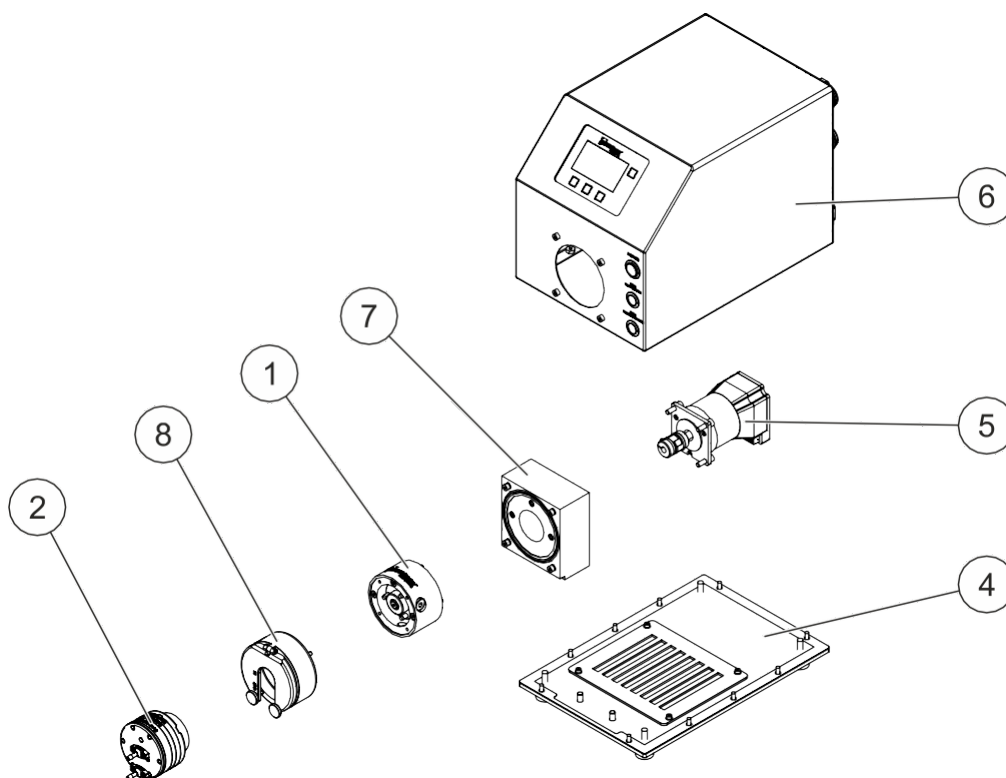

Fig. 3: Sub-assemblies QF30-QCON-EP/-E/-P

Item	Quantity	Designation	
1	1	PQ30A-X01	Ring drive - without motor flange
2	1	QF30DM	Quattroflow QF30SU single-use pump chamber made of PP with 1/8" hose connection
4	1	PQ15E-Q	Base plate long, QF150QCON
5	1	PQ15G-HT-NT	Nanotec motor drive unit - QF150 HT and QCON
6	1	PQ15O-QCON-NT-EP/-E/-P	Housing - QF150QCON
7	1	PQ15T-HT-NT	Motor flange for Nanotec - QF150 HT and QCON
8	1	PQ30W	Feed chamber holder for QF30SU

3.2.4 Ring drive PQ30A-X01

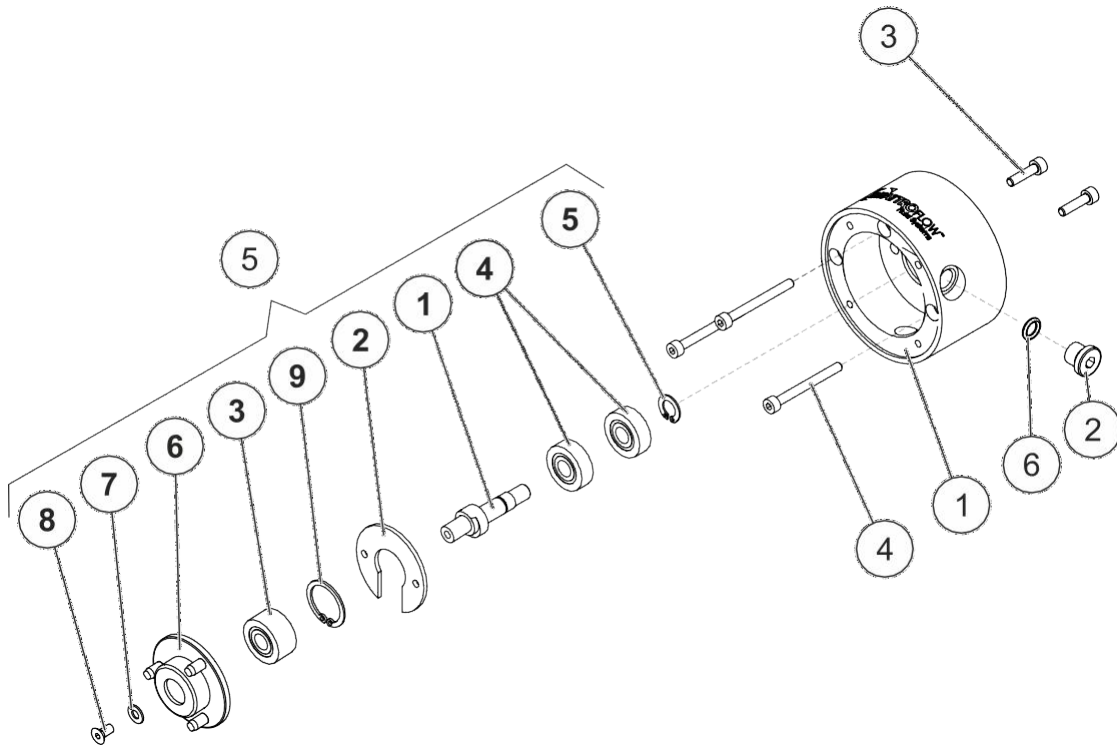

Fig. 4: Sub-assembly ring drive PQ30A-X01

Item	Quantity	Designation	Material	Torque
1	1	Q150-004-06 Bearing shell	1.4571	
2	1	DIN908M10x1 Locking screw	V2A	8.4 Nm
3	2	DIN912M4X16 Cylinder head screw DIN912 M4x16	A2	2.4 Nm
4	3	DIN912M4X40 Cylinder head screw DIN912 M4x40	V2A	2.4 Nm

Item	Quantity	Designation		Material	Torque
5	1	PSKITWLC303	Quattroflow QF30SU maintenance kit, shaft bearing cap unit, 3° shaft, EZ set		
1	1	Q30-008-01	Eccentric shaft 3°	1.4571	
2	1	Q150-006-03	Fixation ring	1.4571	
3	1	30/8B2ZTVH	Angular grooved ball bearing Q150		
4	2	608-ZZ	Grooved ball bearing Q150		
5	1	DIN471 8x0.8	Circlip for Q150 shaft	galvanised	
6	1	Q30-012-01	Sub-assembly bolt cap		
7	1	90415022	Disc	V2A	
8	1	DIN7991M4x8	Countersunk head screw	A2	2.4 Nm
9	1	DIN472 22x1	Circlip DIN472 M22x1	1.4122	
6	1	OR6.5X2NBR70	O-ring 6.5x2	NBR	

### 3.2.5 Pump chamber QF30DM

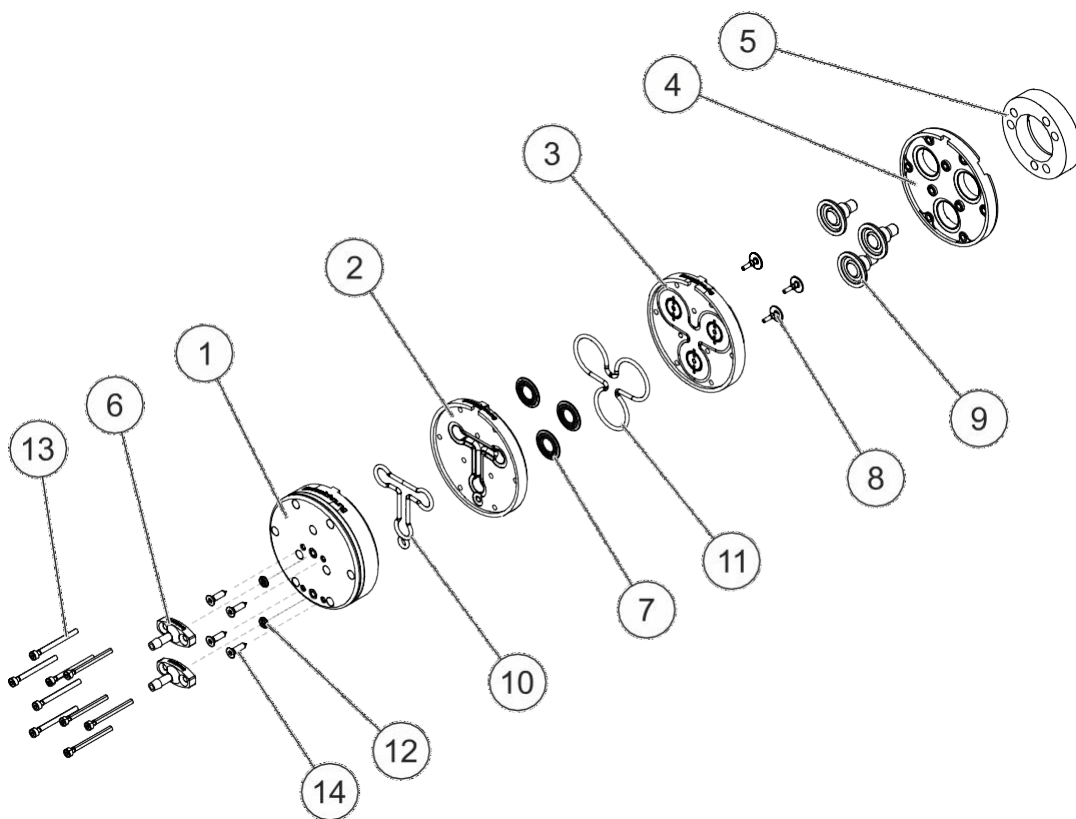

Fig. 5: Sub-assembly pump chamber Quattroflow QF30DM

Item	Quantity	Designation	Material	Torque
1	1	Q30-001-02 Pump housing QF30 SU	PP-DWST	
2	1	Q30-014-01 Centre housing, SU	PP-DWST	
3	1	Q30-002-02 Valve plate, SU	PP-DWST	
4	1	Q30-003-03 QF30SU diaphragm housing lid, sub-assembly	PETP	
5	1	Q30-004-02 Clamping ring	PETP	
6	2	Q30-005-02 Hose connection 1/8" ID 2.5 mm	PP-DWST	
7	3	Q30-010-02 Outlet valve	EPDM	
8	3	Q30-011-02 Inlet valve	EPDM	
9	3	Q150-111-09 QF 150 conveying diaphragm	Santoprene	
10	1	Q30-013-02 Seal PG-MP1	EPDM	
11	1	Q30-013-01 Profile valve plate	EPDM	

Item	Quantity	Designation		Material	Torque
12	2	OR3x1.5	O-ring	EPDM	
13	9	DIN912M2.5x30	Cylinder head screw DIN912 M2.5x30	V2A	0.7 Nm
14	4	SPAXSENK3X12	Countersunk head screw with TORX	V2A, stainless steel	0.7 Nm

**3.2.6 Base plate PQ15E-HT**

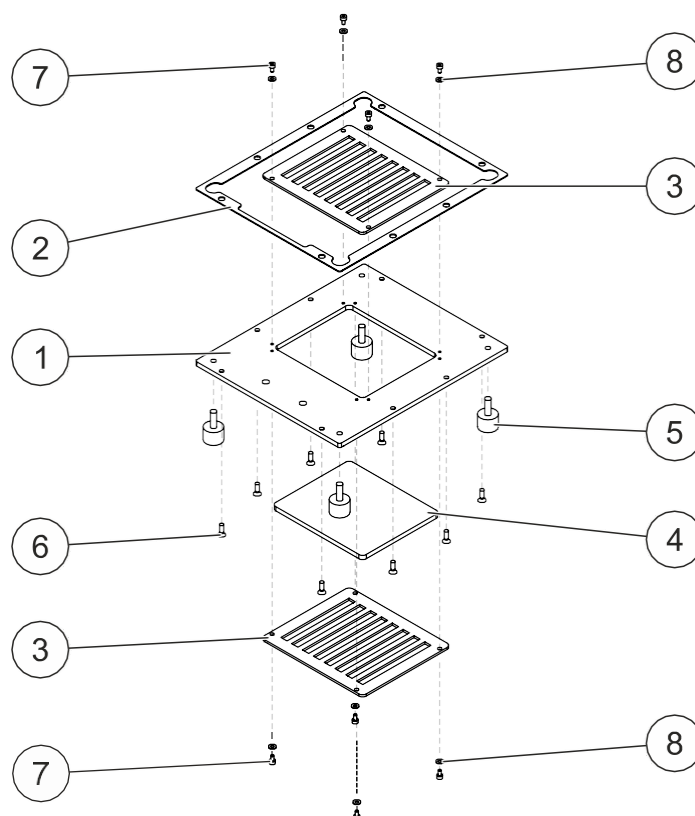

Fig. 6: Sub-assembly base plate PQ15E-HT

Item	Quantity	Designation	Material	Torque	
1	1	Q150-016-08	Base plate HT and QCON, QF150	V2A	
2	1	Q150-019-06	Flat seal for shroud and base plate	EPDM	
3	2	Q150-025-02	Filter mat plate for base plate	V2A	
4	1	Q150-026-01	Filter mat for base plate Q-Control	Synthetic fibre/random fibre fleece	
5	4	GUPUD20x15M6-A2	Rubber-metal buffer		
6	8	DIN965M4X12	Countersunk head screw with cross recess DIN 965, M4 x 12	A2-70	2.4 Nm
7	8	DIN912M3x6	Cylinder head screw DIN912 M3x6	A2-70	1.1 Nm
8	8	DIN125 3.2M3	Washer 3.2 Ø	A2-70	

### 3.2.7 Base plate PQ15E-HT

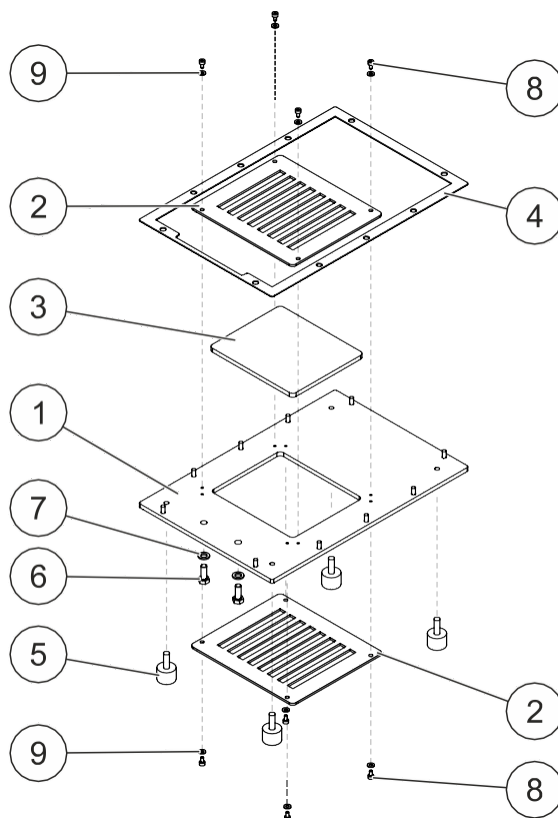

Fig. 7: Sub-assembly base plate PQ15E-Q

Item	Quantity	Designation	Material	Torque	
1	1	Q150-016-07	Base plate long, Q-Control	1.4301	
2	2	Q150-025-01	Filter mat plate for base plate Q-Control	1.4301	
3	1	Q150-026-01	Filter mat for base plate Q-Control	Synthetic fibre/ random fibre fleecce	
4	1	Q150-019-05	Flat seal for shroud Q-Control self-adhesive	EPDM	
5	4	GUPUD20x15M6-A2	Rubber-metal buffer	NR, metal parts made of V2A	
6	2	DIN933M6X16	Hexagon head screw DIN933 M6x16	A2-70	8.4 Nm
7	2	DIN125 6.4M6	Washer 6.4 Ø	V2A	
8	8	DIN912M3x6	Cylinder head screw DIN912 M3x6	A2-70	1.1 Nm
9	8	DIN125 3.2M3	Washer 3.2 Ø	V2A	

### 3.2.8 Drive unit PQ15G-HT-NT

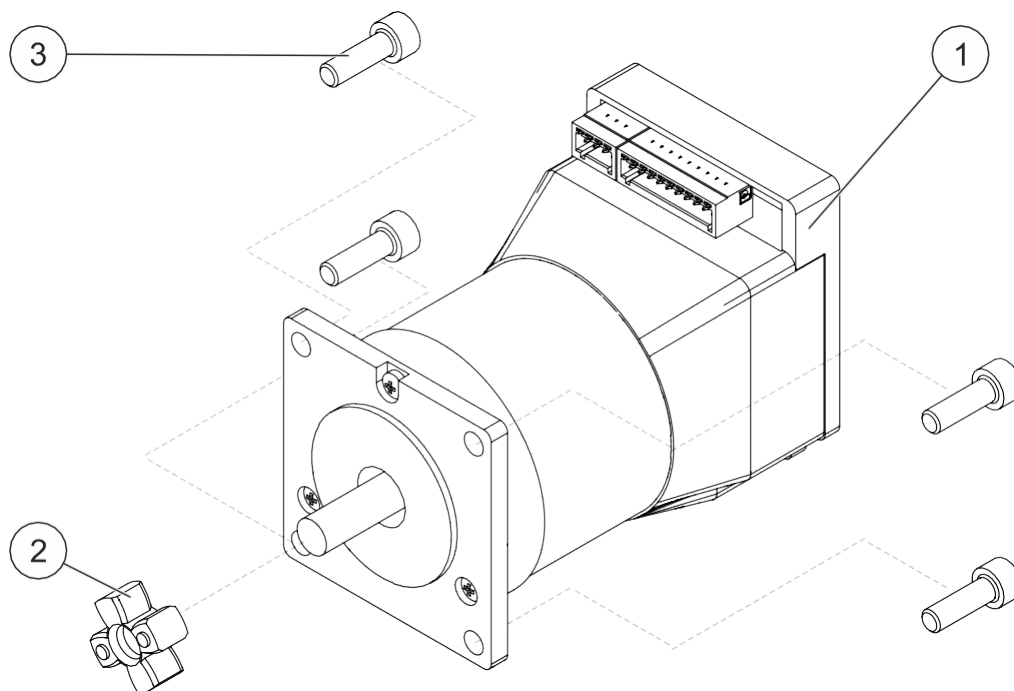

Fig. 8: Sub-assembly drive unit PQ15G-HT-NT

Item	Quantity	Designation	Material	Torque
1	1	Q150-PD4-CB59M Nanotec Servomotor 24 V 135W	Var.	
2	1	KULUØ7-Ø8 Coupling Rotex GS9 (Q150)	Aluminium/polyurethane	
3	4	DIN912M5X16 Cylinder head screw DIN912 M5x16	A2-70	4.9 Nm

### 3.2.9 Motor flange PQ5T-HT

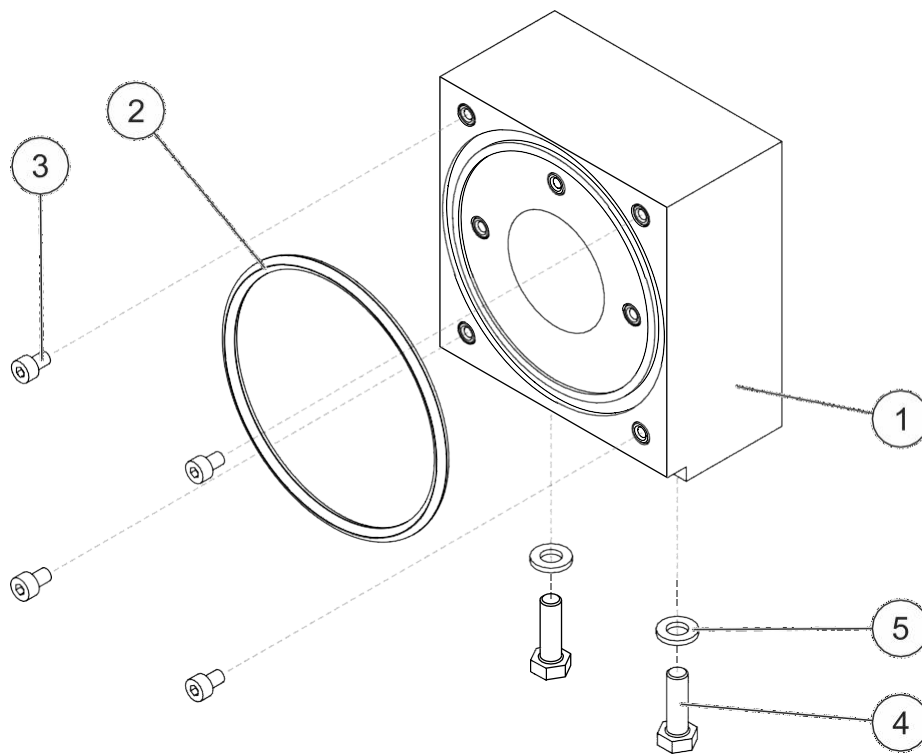

Fig. 9: Sub-assembly motor flange PQ15T-HT-NT

Item	Quantity	Designation		Material	Torque
1	1	Q150-014-16	Motor flange for Nanotec motor	PETP/V2A	
2	1	OR80x4	O-ring	EPDM	
3	4	DIN912M4X6	Cylinder head screw DIN912 M4x6	A2-70	2.4 Nm
4	2	DIN912M6X20	Cylinder head screw DIN912 M6x20	A2-70	8.4 Nm
5	2	DIN125 6.4M6	Washer 6.4 Ø	V2A	

### 3.2.10 Pump conveying chamber PQ30W

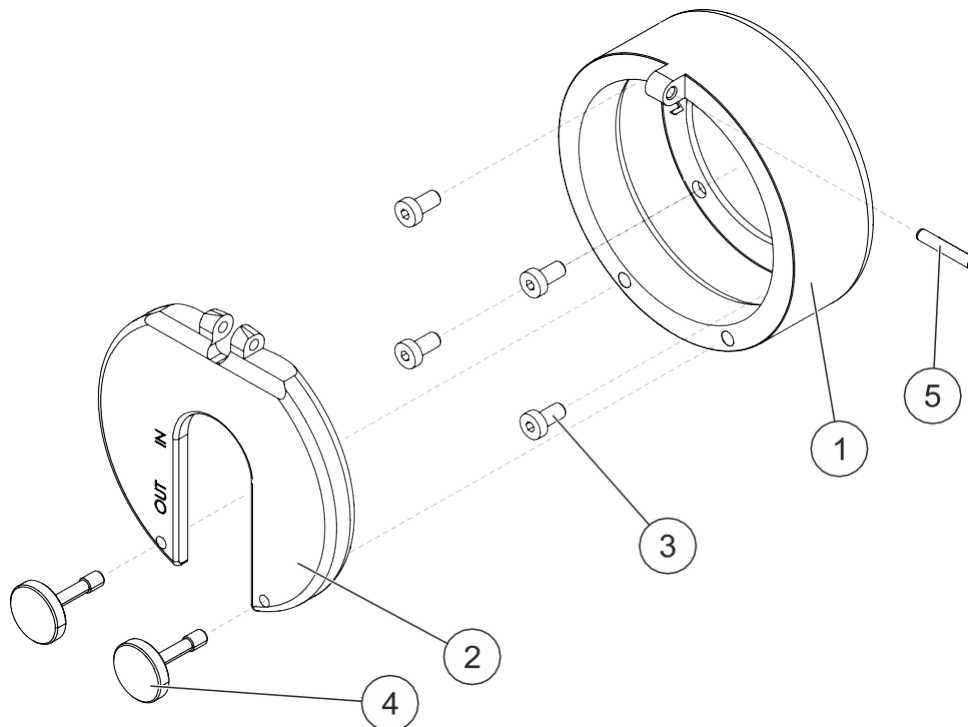

Fig. 10: Sub-assembly pump conveying chamber PQ30W

Item	Quantity	Designation	Material	Torque
1	1	Q30-006-01 Pump chamber holder QF30	1.4301	
2	1	Q30-007-01 Pressure plate QF30	1.4301	
3	4	DIN7984M4X8 Flat cylinder head screw M4x8	A2-70	2.4 Nm
4	2	GN653.2 M4x17 NI Knurled screw V2A M4x17 NI	V2A	
5	1	DIN7 3x18 Cylinder pin DIN7 3x18	V2A	

### 3.3 Motor

The motor settings are configured at the factory. The pump speed can be limited via the control panel.

**ATTENTION** – The enclosed motor operating instructions must be observed.

### 3.4 Performance chart

Conditions:

- Test fluid water at room temperature
- Eccentric shaft 3°
- Pressures 0 to 4 bar
- New diaphragms and new valves
- Under standard conditions

The performance chart shows the approximate delivery rates depending on the pump speed.

Drive: Nanotec

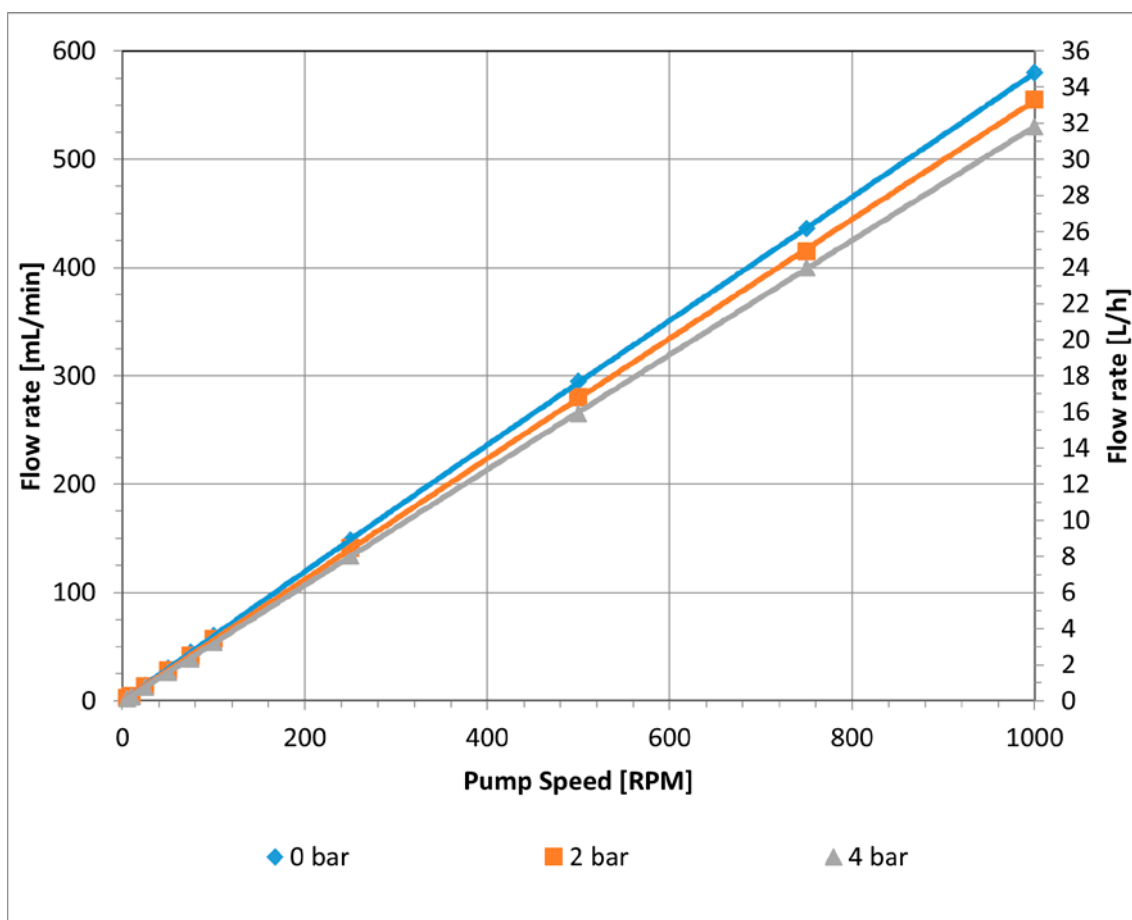

Fig. 11: Performance chart

### 3.5 Water-like fluids

The pump only delivers water-like fluids such as:

- solutions containing protein (albumin, IgG, coagulation factors, monoclonal antibodies, enzymes, vaccines)
- solutions or suspensions containing polymers
- cell suspensions (bacteria, yeasts, algae, fungi, mammal cells)
- colloidal solutions
- virus suspensions, phage suspensions

### 3.6 Labelling

This information is affixed to the pump unit:

- Pump type
- Construction year
- Protection class
- Maximum pumping pressure and hot surfaces
- Speed
- Labelling of connections
- Labelling of direction of flow
- Labelling the pump unit
- Connecting cables, fuses, digital/analogue inputs and outputs (HT/QCON)

Always keep the information in perfectly legible condition.

The type label is affixed to the housing or the base plate.

The serial number is affixed to the top.

### 3.6.1 Pump unit type label

ALMATEC Maschinenbau GmbH  
 Carl-Friedrich-Gauss-Str. 5  
 47475 Kamp-Lintfort, Germany  
 Tel: +49 2842/961-0;  
 quattroflow@almatec.de

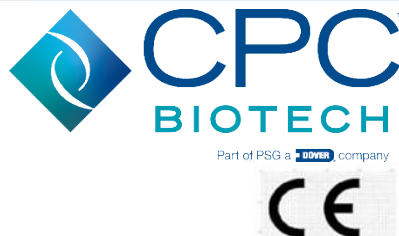

**Type: F6**

Seriennummer: Serial No: <b>F1</b>	Schutzart: System of protection: <b>F4</b>
Nennstrom: Nominal current: <b>F2</b>	Baujahr: Year of construction: <b>F5</b>
Nenn-Spannung: Nominal voltage: <b>F3</b>	

Fig. 12: Example type label

Abbreviation	Specification
F1	Serial number
F2	Rated current in A
F3	Rated voltage in V
F4	IP protection class
F5	Year of construction (month/year)
F6	Pump type

Tab. 1: Information on the type label

### 3.7 Control units

The pump unit can be supplied as a compact version with code HT and QCON with integrated control unit or without control unit.

#### 3.7.1 Control panel HT

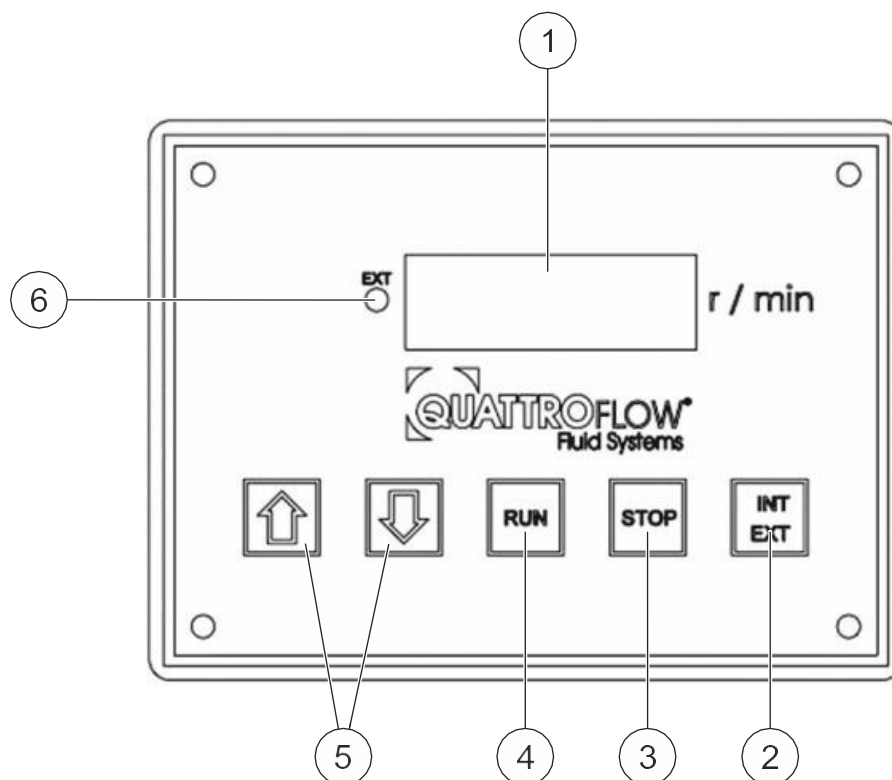

Fig. 13: Control panel HT

Item	Designation	Function
1	Display	Display shows actual speed in rpm
2	Selector switch select control sources INT/EXT	Select the speed control (internal or external)
3	STOP button	Stopping the pump unit
4	RUN button	Starting the pump unit
5	UP/DOWN arrow buttons	Increasing or decreasing the speed
6	LED	Indication that the external control is active

### **Speed limiter**

The motor speed must be increased when converting the pump unit from QF30 <--> QF150 in order to achieve the performance of the pump.

The speed limiter can also be used to adapt the speed to the process requirements.

Set the speed limiter:

- Press and hold the UP and DOWN buttons when starting
- Set the speed with the UP/DOWN buttons
- Confirm with the RUN button – "save" is displayed
- Cancel with the STOP button - "canc" is displayed

### **3.7.2 QControl**

All versions, with an article code containing "QCON" are equipped with the "QControl" control panel. The control panel is covered by a separate operating manual, therefore see the "QControl manual" for further information.

### **3.8 Optional accessories**

These optional accessories are available:

- Leakage sensor (diaphragm monitoring)

## 4 Assembly/installation

**⚠ WARNING** – The eccentric shaft rotates in a housing. There is a risk of crushing in the space in between. Disconnect the pump from the power supply.

Observe the following when setting up the pump unit:

- Set up securely and stably on a non-slip surface able to bear the weight of the pump unit.
- Do not operate in humid or aggressive atmospheres (e.g. in air containing steam, salt or acid) to avoid corrosion on the motor and the control panel.
- Avoid direct exposure to moisture (e.g. spray or water jets) or heat.

### 4.1 Transport and storage

The pump unit is delivered ready for use and packaged. The plastic pump chamber must be installed in accordance with the instructions at Installation/removal, page 32.

**⚠ WARNING** – There is a risk of injury if the pump unit falls. Ensure that the pump unit cannot fall during transport and that it has a secure stand when it is parked.

**⚠ WARNING** – Only store the pump unit under the conditions specified in the technical data in order to prevent damage and leakage of the fluid. Further information can be found in chapter Technical data on page 8.

- ▶ Leave the pump unit and pump in the packaging until the pump unit is used.
- ▶ Protect the pump unit and pump from wet, cold, soiling, UV radiation and mechanical influences.
  - consistently aired, dust and vibration-free room
  - no exposure to heat (sunlight, heating)

## 4.2 Space requirement

Sufficient space must be provided around the pump unit for:

- Ventilation
- Operation
- Maintenance

○

▶ Position the pump so that the control unit is easily accessible.

**NOTE** – Protect the control unit from moisture, spraying and water jets.

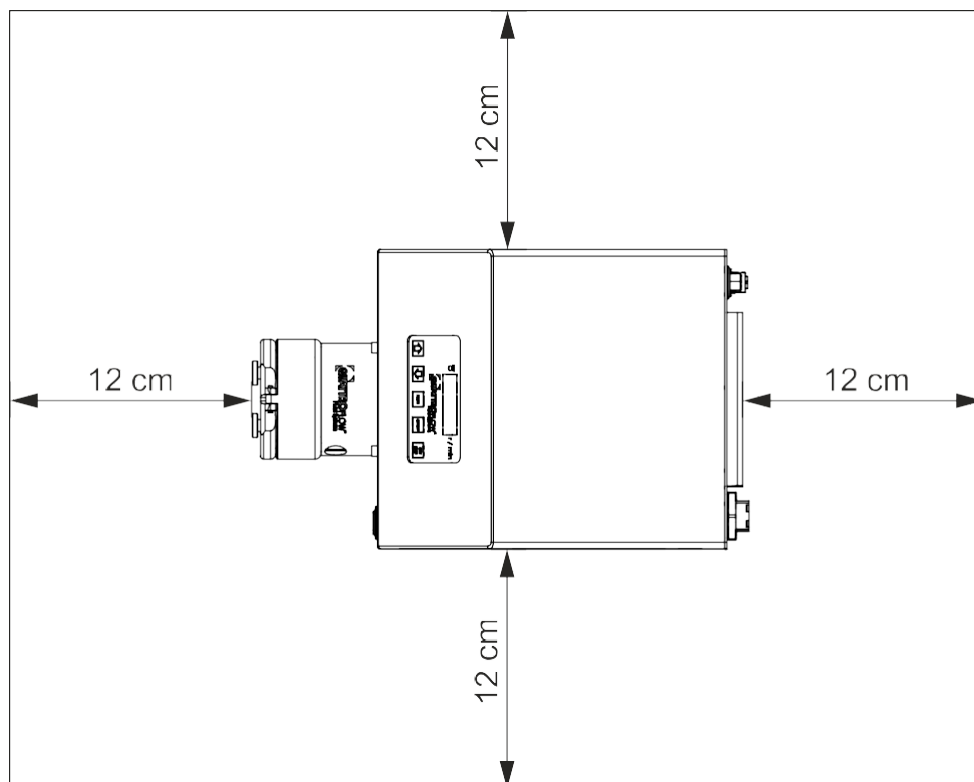

Fig. 14: Space requirement

## 4.3 Connections

### 4.3.1 Pipes

**⚠ WARNING** – If the pressure can rise above the maximum permissible pressure of the pump, a pressure relief valve or automatic pressure cut-out is required.

The pump must be connected with pipes and hoses as follows:

- suction side
  - pipes are adequately dimensioned Too small a pipe cross-section and/or an unfavourable mechanical flow design (e.g. many pipe elbows) can lead to a reduced pump performance and to cavitation.
  - pipes withstand the vacuum pressure and do not collapse
  - pipes withstand the fluid temperatures
- pressure side
  - pipes are adequately dimensioned
  - for the pumping and operating pressure
  - the operating and fluid temperature

### 4.3.2 Electric cables

**⚠ DANGER** – Electric shock due to electrical voltage. Touching electrical components can cause fatal electric shock. The pump may only be connected by experts. Disconnect the pump from the power supply before working on it.

- ▶ Pull out the mains plug.
- ▶ Disconnect all phases of the pump unit from the mains.

**NOTE** – Only operate the pump unit with the mains voltage and mains frequency specified in the technical data (see Technical data, page 8) to prevent damage to the control unit and drive (see Labelling, page 25).

- ▶ Connect the pump unit to a protective earth system.
  - Minimum cross-section 1.5 mm<sup>2</sup> (AWG14)
  - Protected against mechanical damage over the whole length
- ▶ Install the pump unit with a suitable preliminary fuse.
  - Residual current circuit breaker (RCCB)
  - Plug connections must be suitable for industrial applications in accordance with IEC 60309.
- ▶ If the risk analysis demands, integrate the pump into an emergency stop system via its electrical connection.

### 4.3.3 Collection vessel

**⚠ CAUTION** – Fluid can spill if the diaphragm bursts. The fluid escapes through a hole in the ring drive. Place a collection vessel under the ring drive.

**NOTE** – If the pump unit is operated unsupervised for a long period of time, the special leakage sensor accessory is recommended for diaphragm monitoring. This applies especially for pumping dangerous fluids.

- ▶ If you have any further questions regarding diaphragm monitoring, contact the Service Department.

## 4.4 Parameter settings

A separate operating manual is available for pump units with the QCON control panel.

## 5 Installation/removal

**⚠ DANGER** – Electric shock due to electrical voltage. Touching electrical components can cause fatal electric shock. Disconnect the pump from the power supply before working on it.

- ▶ Pull out the mains plug.
- ▶ Disconnect all phases of the pump unit from the mains.

**⚠ WARNING** – Electrical and mechanical hazards. Ensure that the pump unit is in a safe condition:

- emptied
- flushed
- depressurised
- cooled
- voltage-free

The suction and pressure side lines must be closed and emptied if necessary. If the pump is removed, a note about the last pumped fluid or a decontamination certificate must be enclosed.

**⚠ WARNING** – Risk of burns The pumped fluid and cleaning products can heat up parts of the pump. Do not touch the pump. Allow the pump to cool down.

**⚠ WARNING** – Risk of injury After completing the work, all safety and protective equipment must be reinstalled or put back into operation. Before starting up again, the points listed in the chapter Commissioning, page 35, must be observed and the pump must be checked for leaks.

**NOTE** – Torques can be found in the information contained in chapter Sub-assemblies, page 12.

### 5.1 Assembling the pump chamber

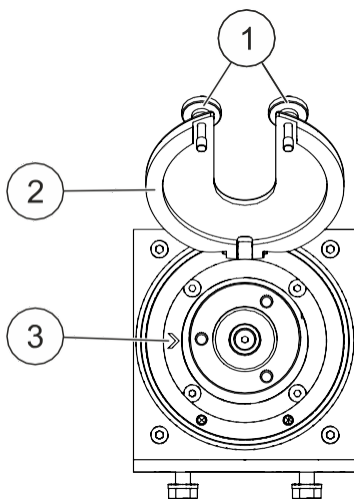

- ▶ Loosen the screws (1).
  - ▶ Fold up the pressure plate (2).
- ATTENTION** – Marking (3) must be in the correct position.

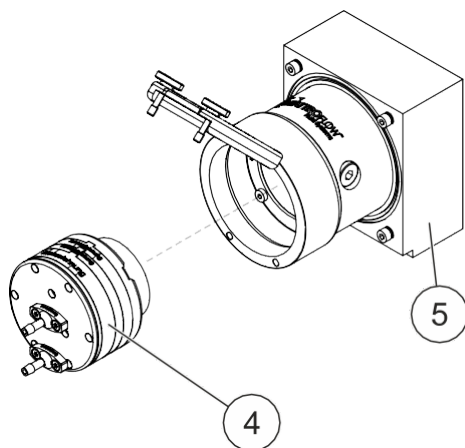

- ▶ Insert the pump chamber (4) into the ring drive (5).

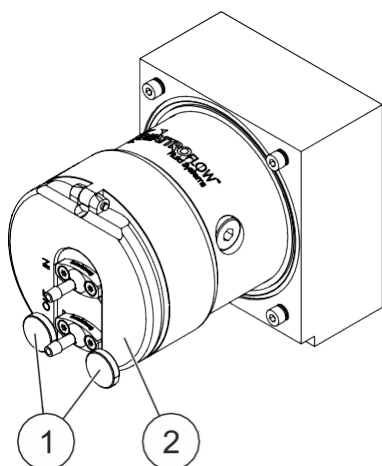

- ▶ Collapse the pressure plate (2).
- ▶ Fasten the screws (1).

## 5.2 Disassembling the pump chamber

---

- ▶ Loosen the screws (1).
- ▶ Fold up the pressure plate (2).

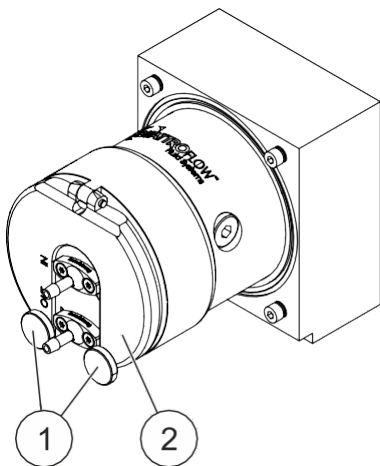

- 
- ▶ Pull the pump chamber (3) forwards off the ring drive (4).

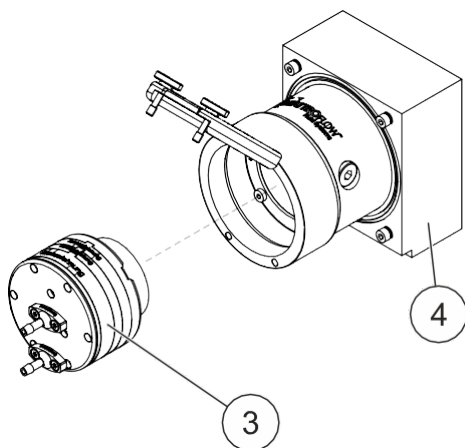

## 6 Commissioning

Before operating for the first time, fill the pump with 0.1 N to 0.5 N NaOH solution and allow the solution to soak in. The soaking time depends on the desired result (e.g. depyrogenation 10 to 20 hours). Adapt the flushing and cleaning procedure to the respective application and check the effect by suitable analytical processes.

### 6.1 Test run

**NOTE** – A test run must be carried out before using the pump for the first time..

- ▶ Carry out a test run with a safe fluid, e.g. water.
- ▶ Check the suitability of the pump by performing representative preliminary tests..  
Check the compatibility of the pump with the fluid to be pumped. Fluids containing oil or solvents can lead to swelling or destruction of the elastomer materials. Check this component especially:
  - Pump chamber (Further information can be found in chapter Pump chamber QF30DM on page 17.)
- ▶ If in doubt, consult the Material and Certification Guide or our Service Department.

## 7 Operation

### 7.1 Safety

**⚠ DANGER** – Risk of chemical burns. The use of strong alkaline solutions can lead to chemical burns. Wear protective goggles, safety gloves and protective clothing. Observe the safety data sheet of the fluid used.

**⚠ WARNING** – Risk of burns The pumped fluid and cleaning products can heat up parts of the pump. Do not touch the pump. Allow the pump to cool down.

**⚠ WARNING** – Only operate the pump with the pump chamber and housing mounted. Do not operate the pump if the pump or one of its components is damaged.

**⚠ WARNING** – Operation in a closed circuit at low flow rates can result in an impermissible temperature increase in the pumped fluid.

**⚠ WARNING** – Do not fall below the permissible negative pressure on the suction side as specified in the chapter Technical data, page 8.

**⚠ WARNING** – On exceeding the maximum permissible pressure, the conveying diaphragm can tear and fluid can spill. Make sure that the suction and pressure lines are adequately dimensioned. Only apply pressure to the pump chamber when the pump chamber is mounted on the drive.

The maximum permissible pumping pressure depends on the temperature of the pumped fluid (see Technical data, page 8).

**⚠ WARNING** – Risk of injury Never operate the pump unit without a coupling guard or motor shroud.

**ATTENTION** – Damage to the pump due to cavitation if the permissible negative pressure on the suction side is exceeded.

**ATTENTION** – Only operate the pump unit with the mains voltage and mains frequency specified in the see Technical data, page 8 to prevent damage to the control unit and drive of the pump unit.

### 7.2 Switching on

**⚠ WARNING** – Overpressure can lead to leakages and spillage of the fluid. It is possible to be exposed to a dangerous fluid or to be scalded. Never switch the pump unit on if the pressure side might be closed.

- ▶ Check the system in advance for possible leakages and visible damage.
- ▶ Open the pressure line.
- ▶ Flush the pump before each use and condition it with a product-compatible solution (e.g. buffer).

### 7.3 Shutdown

Shut down the pump unit if necessary.

- ▶ Empty the pump.
- ▶ Disconnect the pump unit from the power source.

**⚠ WARNING** – The operator must provide a suitable device for disconnecting the pump unit from the power source.

## 7.4 Operation with the control panel HT

The pump unit with the control panel HT can be operated in two ways:

- Manual operation (speed setting and start/stop) of the pump unit by the control panel (see Control panel HT, page 27)
  - External operation of the pump unit:
    - Speed control via analogue input signal (4-20 mA)
    - Pump start/stop via potential-free contact
- The buttons of the control panel are locked.

Int/Ext button rear	Int/Ext push-button panel (Ext = LED EXT (6) on)	Speed control via	Start/Stop via
Int	Int	Panel	Panel
Int	Ext	Ext	Panel
Ext	Ext	Ext	Ext

Tab. 2: Operation with the control panel HT

### 7.4.1 Starting the pump unit

#### Manual operation

An overview of the control unit can be found in chapter Control panel HT, page 27.

- ▶ Set the INT/EXT selector switch (2) on the rear of the pump to INT.
- ▶ Switch on the pump.
- ▶ Press the arrow buttons (5) to set the desired speed. The desired speed appears as a target value on the display (1).
- ▶ When you have set the desired speed, press the RUN button (4).
- ▶ Press the STOP button (3) to stop the pump unit.

#### External operation

- ▶ Set the INT/EXT selector switch (2) on the rear of the pump to INT.
- ▶ Switch on the pump.
- ▶ Signal connection (8-pin plug) + start/stop signal

**NOTE** – The start and stop signal must always be used. For the plug specification see see Technical data, page 8.

#### 7.4.2 Stopping the pump unit

- ▶ Press the STOP button (3).
- ▶ Wait until no more fluid is pumped.

#### 7.4.3 Switching off the pump unit

- Stop the pump unit.
- ▶ Empty the pump.
- ▶ Switch off the pump unit using the main switch. This causes the display to go blank.

**⚠ WARNING** – Risk of burns The fluid can heat up parts of the pump unit. Do not touch the pump. Allow the pump to cool down.

- ▶ Clean the pump.

#### 7.4.4 Setting the speed

An overview of the control unit can be found in chapter Control panel HT, page 27.

- ▶ Set the speed using the arrow buttons (5).
  - The UP arrow button increases the speed.
  - The DOWN arrow button reduces the speed.

## 8 Maintenance

### 8.1 Safety

**⚠ DANGER** – Risk of chemical burns. The use of strong alkaline solutions can lead to chemical burns. Wear protective goggles, safety gloves and protective clothing. Observe the safety data sheet of the fluid used.

**⚠ DANGER** – Electric shock due to electrical voltage. Touching electrical components can cause fatal electric shock. Disconnect the pump from the power supply before working on it.

- ▶ Pull out the mains plug.
- ▶ Disconnect all phases of the pump unit from the mains.

**⚠ WARNING** – Electrical and mechanical hazards. Ensure that the pump unit is in a safe condition:

- emptied
- flushed
- depressurised
- cooled
- voltage-free

The suction and pressure side lines must be closed and emptied if necessary. If the pump is removed, a note about the last pumped fluid or a decontamination certificate must be enclosed.

**⚠ WARNING** – Risk of burns. The pumped fluid and cleaning products can heat up parts of the pump. Do not touch the pump. Allow the pump to cool down.

**⚠ WARNING** – Risk of injury. After completing the work, all safety and protective equipment must be reinstalled or put back into operation. Before starting up again, the points listed in the chapter Commissioning, page 35, must be observed and the pump must be checked for leaks.

**ATTENTION** – Bearing wear. A diaphragm rupture can result in increased wear of the bearing as well as heating. Replace the pump bearings after diaphragm rupture.

## 8.2 Maintenance intervals

Wear parts, such as the pump chamber, must be replaced at regular intervals in the course of preventive maintenance.

The recommended intervals were determined under standardised conditions.

- Fluid: Water
- Fluid temperature: 20°C
- Ambient temperature: 20°C
- Flow rate: 24 lph
- Counter pressure: 4 bar

If conditions are different, e.g. higher fluid temperatures, the component service life must be determined by the operator in process-related preliminary tests and a regular visual inspection or detailed inspection must be performed. Depending on the application, the maintenance intervals must be shortened.

- ▶ Check the intervals close to the process and adapt the recommended intervals to the application and the pumped fluid.
- ▶ Use only original spare parts.

Recommended interval	Component	Activity
After diaphragm breakage or 1000 operating hours or at least once a year	Pump chamber	Replace (available as a replacement kit)
	WLC unit <ul style="list-style-type: none"> <li>• Eccentric shaft</li> <li>• Bearing unit</li> <li>• Cap</li> </ul>	Replace (available as a pre-assembled replacement kit)
In the event of corrosion, fluid in the bearing shell or a clearly audible running noise	WLC unit <ul style="list-style-type: none"> <li>• Eccentric shaft</li> <li>• Bearing unit</li> <li>• Cap</li> </ul>	Replace (available as a pre-assembled replacement kit)

### 8.3 Replacing the WLC unit

- ▶ Dismantle the pump chamber (see Disassembling the pump chamber, page 34).
- ▶ Remove the screws (1).
- ▶ Pull the pump conveying chamber (2) forwards off the ring drive (3).

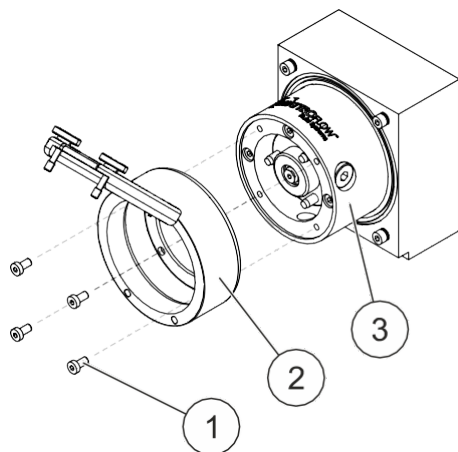

- ▶ Remove the screws (4).
- ▶ Pull off the ring drive (3) forwards off the motor flange (5).

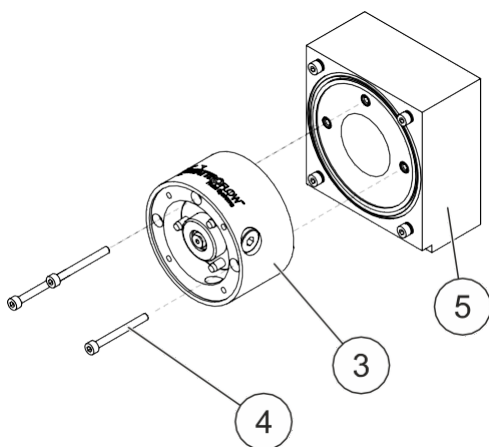

- ▶ Remove the screw (6) in the coupling half (7).

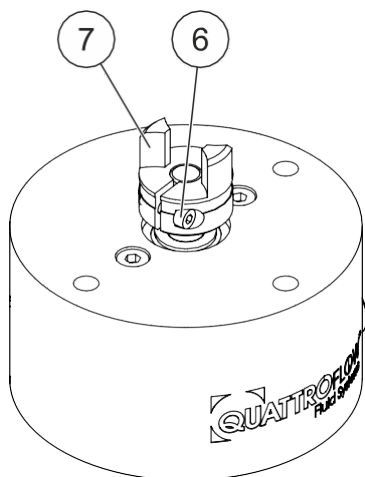

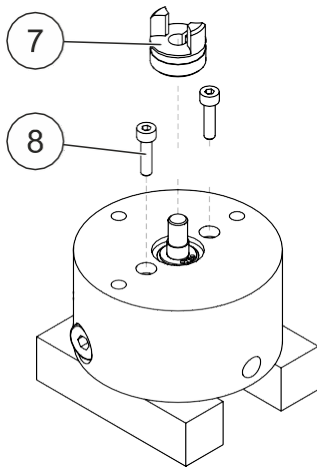

- ▶ Remove the coupling half (7).
- ▶ Remove the screws (8).

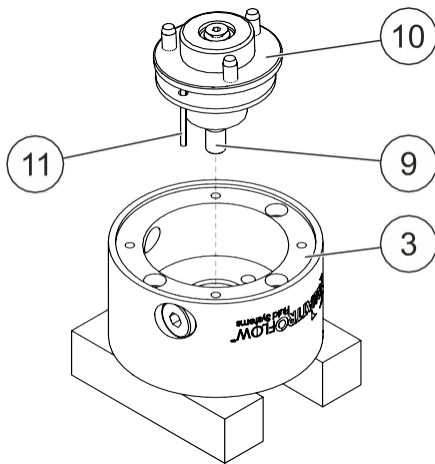

- ▶ Turn the ring drive (3).
- ▶ Place the ring drive so that the shaft (9) is not under load.
- ▶ Remove the WLC unit (10) from the ring drive.
- ▶ Mount the assembly bolt supplied (11) on the new unit.
- ▶ Insert the new WLC unit (10) into the ring drive.

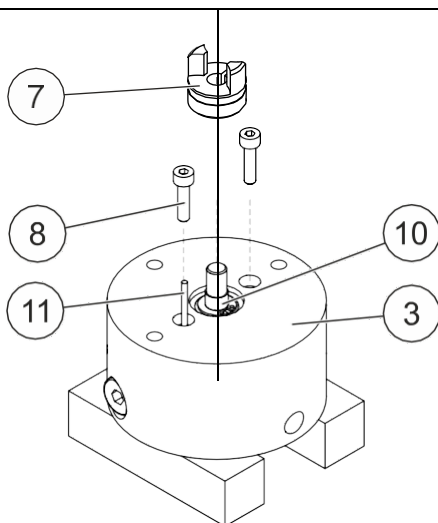

- ▶ Turn the ring drive (3).
- ▶ **ATTENTION** – The WLC unit (10) may fall out. Hold the WLC unit (10) in place.
- ▶ Secure the WLC unit (10) using the assembly bolt (11).
- ▶ Fasten the first screw (8).
- ▶ Unscrew the assembly bolt (11).
- ▶ Fasten the second screw (8).
- ▶ Tighten both screws (8).
- ▶ Push the coupling half (7) onto the shaft.

- ▶ Fit the ring drive (3) onto the motor flange (5).

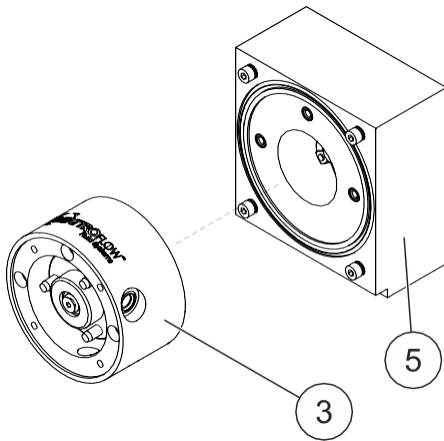

- ▶ The end of the coupling half (7) and the shaft (9) of the drive (12) must match.
- ▶ Fit the sprocket wheel (13) onto one of the coupling halves (7).
- ▶ Insert the two coupling halves (7) into each other as shown.

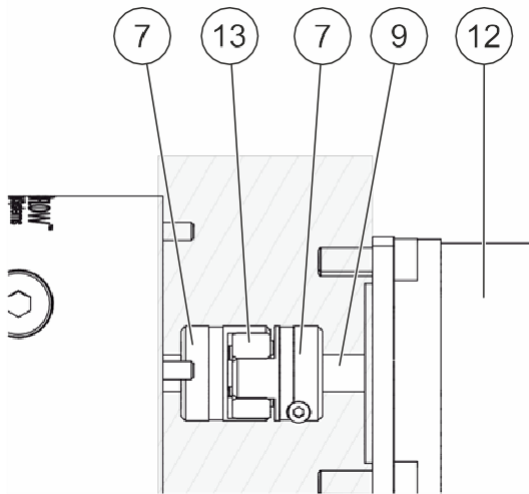

- ▶ Fasten the screws (4).

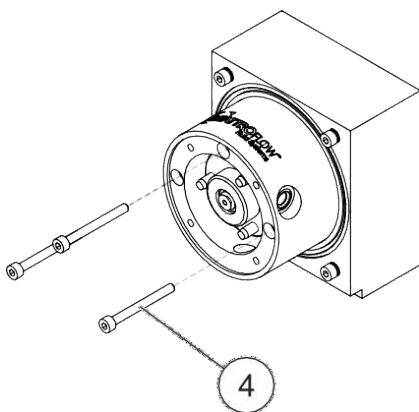

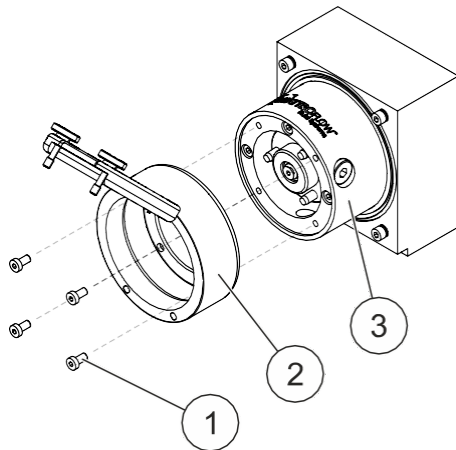

- ▶ Fit the pump conveying chamber (2) onto the motor flange (3).
- ▶ Fasten the screws (1).
- ▶ Assemble the pump chamber (see Assembling the pump chamber, page 33).

## 8.4 Cleaning

The cleaning procedure must be adapted accordingly to the used products and the prevailing conditions. The user is responsible for checking the cleaning result.

### 8.4.1 Gamma radiation

In the gamma sterilisation process, cobalt-60 or X-radiation is used to kill micro-organisms on and in the product.

## 9 Malfunctions

### 9.1 Elimination of faults

The 4-piston diaphragm pump works very reliably and error-free when it is used, serviced and operated according to the operating manual.

Troubleshooting										Cause of fault/remedy
	Pump does not start.	Pump sucks poorly or not at all	Delivery volume is not achieved	Counter - pressure is not achieved	Delivery volume is uneven.	Running noises get louder	Pump is leaking	Motor too hot	Display shows error code or is off	
1		X					X			The screws connecting the individual components are not tightened properly. – Tighten the screws.
2		X								The pump has wrong direction of flow. – Switch the suction and pressure sides.
3		X	X		X					Air in the pumped fluid, e.g. due to a leaking TC seal – Check the pipes for leaks.
4		X	X	X	X					The components in the suction side are wrong. – Check all pipes, hoses and valves.
5		X	X		X					Check the viscosity of the fluid.
6	X								X	Check supply lines, power supply and fuses F1 and F2 in the control unit. – Replace components.
7			X	X	X					Avoid air in the pumped fluid. – Tighten all clamps.
8			X		X					Check components in the pressure side.
9							X			The pressure side is sealed. – Check the components of the pressure line(s).

Troubleshooting										Cause of fault/remedy
	Pump does not start.	Pump sucks poorly or not at all	Delivery volume is not achieved	Counter - pressure is not achieved	Delivery volume is uneven.	Running noises get louder	Pump is leaking	Motor too hot	Display shows error code or is off	
10			X							The pipe cross-sections are too small. – Replace pipes.
11						X				The coupling halves are too close together. – Leave a clearance of 1 mm.
12						X				The connecting element of the coupling is worn. – Replace the connecting element.
13		X	X		X					Check whether foreign bodies have entered the pump.
14	X							X	X	Thermal circuit breaker in the motor has tripped. – Allow the motor to cool down and reduce the motor power if necessary.
15	X					X				Shaft bearings are defective. – Replace the shaft bearings.
16		X								Valves are dry (long standstill), deformed or otherwise defective. – Replace the pump chamber.
17							X			Conveying diaphragm is torn (usually the pumping pressure is too high). – Replace the pump chamber.
18		X	X	X			X			O-rings between valve plate and pump housing are defective. – Replace the pump chamber.
19						X				Alignment of the pump with the drive is not correct. – Correct the alignment.
20			X			X				The screw of the clamping ring is not tightened properly. – Tighten the screw.
21	X								X	The parameters of the control panel are wrong. – Check the basic settings.

## 9.2 Return

- ▶ Decontaminate the pump completely.
- ▶ Fill in the decontamination certificate.
  - The decontamination certificate is enclosed with the pump unit.
  - Observe the safety notes on the decontamination certificate.
  - The manufacturer will not accept the pump without a decontamination certificate.
- ▶ Contact the Service Department (see Manufacturer and Service, page 3).

## 10 Disposal

The pump unit basically consists of the following materials:

- Steel and stainless steel
- Non-ferrous metal
- Plastic - especially elastomers (see Technical data, page 8)
- Electronic modules

Improper disposal of materials (e.g. metals, plastics, electrical and electronic modules) leads to environmental pollution. Recyclable materials must be recycled in an environmentally friendly manner.

Consult the manufacturer to return them. Further information can be found in chapter Return on page 47.

Alternatively, disposal can also be carried out by a commercial disposal company and in accordance with national regulations.

The pump unit is marketed under the WEEE number 97509452.

## 11 Glossary

- 4-piston diaphragm pump  
Pump with a diaphragm containing 4 enclosed volumes which deliver one after another in a revolution to reduce the pulsation.
- Dosing pump  
Positive displacement pumps deliver defined volumes per revolution independently of the pressure conditions at the input and output of the dosing pump.
- Depyrogenation  
Removal of pyrogens from a solution
- Pump chamber  
Parts of the pump that come into contact with the fluid.
- Gamma radiation  
In the gamma sterilisation process, cobalt-60 or X-radiation is used to kill micro-organisms on and in the product.
- Enclosed volume  
Space created by movement of the diaphragm which serves to displace the fluid.
- Diaphragm  
Force-transmitting seal to deliver liquid media
- Diaphragm support  
Component mounted on the back of the diaphragm and connecting the clamping ring to the diaphragm
- ▶ Assembly bolt  
Extra long diaphragm end to ensure easier installation
- Pump (pump head)  
Pump with free shaft end  
Oscillating positive displacement pump without drive
- Pump unit  
Liquid pump connected to a drive, including power transmission unit, base plate and additional equipment
- Residual volume  
Fluid volume that can remain in the pump after running empty
- Recirculation pump  
Pump for delivering and circulating certain fluids
- Single use (SU)  
Single-Use, single use of the pump chamber, plastic
- Dry suction height  
Suction lift of the pump with unfilled pump chamber
- Positive displacement pump  
Positive displacement pump is the generic term for all pumps that work according to the displacement principle. It is also referred to as volumetric pump and delivers the fluid in a self-enclosed volume.
- WLC unit  
Pump spare part



Subject to modifications, 2024-05 (first edition)

**PSG Germany GmbH**  
**Hochstraße 150-152 | 47228 Duisburg | Germany**  
**Phone +49 2065 89205-0**  
[www.cpc-bio.com](http://www.cpc-bio.com) | [info@cpc-bio.com](mailto:info@cpc-bio.com)