

BioProTT™ FlowSU System User Manual

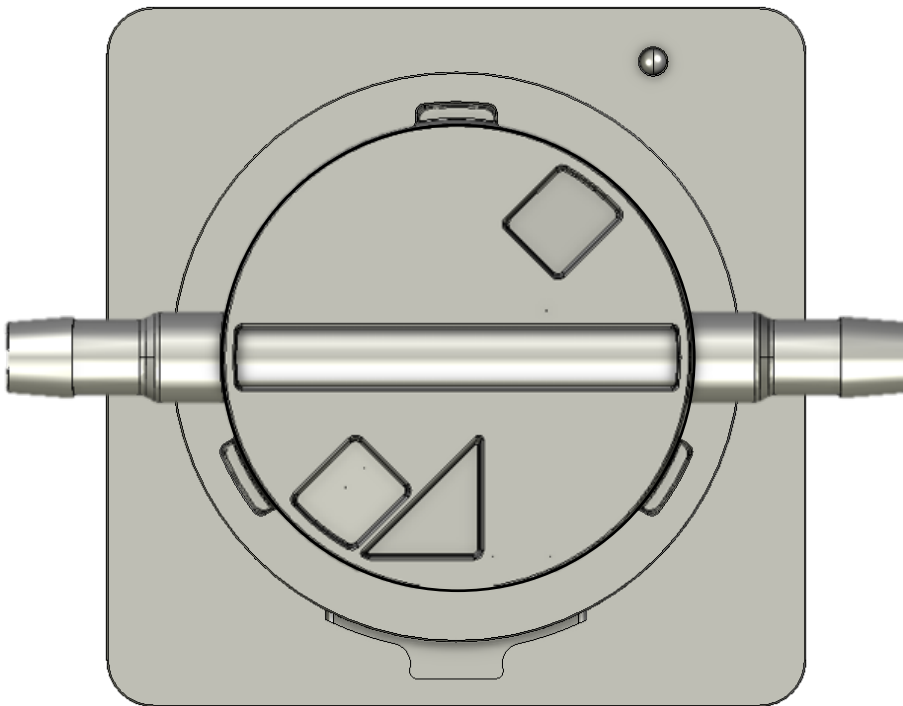

Copyright

All rights reserved, especially with respect to reproduction, distribution and translation. This user manual or any part thereof must not be reproduced, saved, processed, duplicated or distributed without the written consent of em-tec GmbH.

© Copyright 2025 em-tec GmbH Finning. –All rights reserved.

Subject to Technical Changes

Owing to our policy of continuous product development, the illustrations and technical data contained in this document may differ slightly from the current version of the device.

Legal Manufacturer

em-tec GmbH
Lerchenberg 20
86923 Finning
GERMANY

Telefon: +49 8806 9236 0
Fax: +49 8806 9236 50
E-Mail: em-tec-info@psgdover.com
Internet: www.em-tec.de

UK Representative

Obelis UK Ltd.
Sandford Gate
East Point Business Park Oxford
OX4 6LB, United Kingdom

Telefon: +44 1865 910 145
E-Mail: info@obelis.co.uk



Table of Contents

1	Symbols, Units and Abbreviations	5
1.1	Symbols used in these Operating Instructions	5
1.2	Symbols on Multi-Use Part and on Packaging	5
1.3	Symbols on Single-Use Sensor and on Packaging	6
1.4	Definitions and Abbreviations	8
2	General Information	9
3	Intended Purpose and Restrictions	10
3.1	Intended Purpose	10
3.2	Usage Restrictions and Limitations	10
3.3	Liabilities and Responsibilities	10
3.4	Safety Instructions	11
3.5	Notice Concerning Compulsory Registration	11
3.6	RoHS and REACH	11
3.7	Electrical Safety and Electromagnetic Compatibility	11
3.8	Maintenance and Service	12
4	Description of the Measurement Principle	13
5	Scope of Supply	13
6	BioProTT™ FlowSU System Description	14
6.1	BioProTT™ FlowSU System	14
6.2	BioProTT™ FlowSU Sensor	16
7	Installation and Setup of the BioProTT™ FlowSU System	17
7.1	Mounting of the BioProTT™ FlowSU System	17
7.2	Installation Position of the BioProTT™ FlowSU System	18
7.3	Connecting the BioProTT™ FlowSU System to the Host System	18
7.4	Unpacking and Installing the BioProTT™ FlowSU Sensor	19
7.4.1	Unpacking the BioProTT™ FlowSU Sensor	19
7.4.2	Inserting the BioProTT™ FlowSU Sensor into the BioProTT™ FlowSU System	19
7.4.3	Attaching the Tube to the BioProTT™ FlowSU Sensor	20
8	Initialization and Start-Up of the BioProTT™ FlowSU System	20
9	Integration Information	21
9.1	Additional Uses of the BioProTT™ FlowSU System	21
9.2	Use of Status Information	22
9.2.1	Coupling Value	22
9.2.2	Bubble Detection	22



10	Web Interface of the BioProTT™ FlowSU System	23
10.1	Main Web Page for the BioProTT™ FlowSU System	23
10.2	Sensor Information Page for the BioProTT™ FlowSU Sensor	25
10.3	Configuration Page of the BioProTT™ FlowSU System	27
10.4	Logging Page of the BioProTT™ FlowSU System	30
11	Modbus Interface	31
11.1	Read Input Register (Function Code: 0x04)	31
11.2	Additional Information Regarding the Read Input Register (Function Code: 0x04)	32
11.3	Read Discrete Inputs (Function Code: 0x02)	35
11.4	Write Coil (Function Code: 0x05)	35
11.5	Read Coil (Function Code: 0x01)	36
11.6	Write Register (Function Code: 0x06)	36
11.7	Read File Record Register (Function Code: 0x14)	36
12	Totalizer	37
13	Calibration	38
13.1	Calibration Table	38
13.2	Calibration Factor	39
13.2.1	Determining the Calibration Factor	39
13.2.2	Setting the Calibration Factor	39
14	On-Site Adjustment & Factory Settings	39
14.1	On-Site Adjustment	39
14.2	Factory Settings	39
15	Cleaning and Disinfection of the BioProTT™ FlowSU System	40
16	Troubleshooting	41
16.1	General Troubleshooting	41
16.2	Errors and Warnings Originating from the Flow Measurement Board	41
16.3	Global Errors and Warnings Originating from the Flow Measurement Board	46
16.4	Other Troubleshooting	48
16.5	Status Information Troubleshooting	50
17	Environmental Protection and Disposal	53
18	Contact Information for Technical Support	53
19	Technical Specifications of the BioProTT™ FlowSU System	54
19.1	BioProTT™ FlowSU System	54
19.2	BioProTT™ FlowSU Sensor	55
19.3	Accuracy of the BioProTT™ FlowSU System	57
	Annex: Qualification Handbook	58

1 Symbols, Units and Abbreviations

1.1 Symbols used in these Operating Instructions













Symbol	Meaning
	Warning! This safety symbol precedes critical information that must be strictly observed in order to prevent injuries and fatal hazards. This warning symbol is the most important safety symbol.
	Caution! Important information regarding correct handling. Must be performed and strictly observed! If this information is not observed, faults or damage to the product or its surroundings may occur.

Table 1: Symbols Used in these Operating Instructions

1.2 Symbols on Multi-Use Part and on Packaging

Symbol	Meaning
	Read this user manual carefully before use. Keep it in an easily accessible location for future reference. Replacement copies of this user manual are available from the manufacturer.
	Do not dispose of this device as domestic waste! Waste devices must be disposed of in accordance with WEEE Directive 2012/19/EU and national legislation.
	Manufacturer em-tec GmbH · Lerchenberg 20 · 86923 Finning · Germany
	Serial number
	Order/ article number (=ID)
	The manufacturer declares the conformity of the device with the applicable European Regulations and Directives.
	SGS North America Certification Mark: the manufacturer declares that the product complies with the American and Canadian standards in force (e.g. ANSI/AAMI ES60601-1, CAN/CSA C22.2 No.60601-1, ANSI/UL 60950-1, ANSI/UL 61010-1)
	UK Conformity Assessed UK Representative: Obelis UK Ltd, Sandford Gate, East Point Business Park Oxford, OX4 6LB, United Kingdom Phone: +44 1865 910 145 E-Mail: info@obelis.co.uk
	Caution, fragile! Handle with care!
	Protect against moisture! Store in a dry place.













Symbol	Meaning
	This side up!
	Temperature limit during storage and/or transport
	Moisture limit during storage and transport (non-condensing)
	Air pressure limit during storage and transport
	Storage
	Transport
	QR code containing the following product details: <ul style="list-style-type: none"> - ID - country of origin - serial number - manufacturer address
Made in Germany	information about country of origin
[...] L-VX.X	label revision/version
	PoE: The BioProTT™ FlowSU System must only be used with a PoE injector that is managed and galvanically isolated.

Table 2: Symbols on Multi-Use Part and on Packaging

1.3 Symbols on Single-Use Sensor and on Packaging

Symbol	Meaning
	Read this user manual carefully before use. Keep it in an easily accessible location for future reference. Replacement copies of this user manual are available from the manufacturer.
	Do not dispose of this device as domestic waste! Waste devices must be disposed of in accordance with WEEE Directive 2012/19/EU and national legislation.
	Manufacturer em-tec GmbH · Lerchenberg 20 · 86923 Finning · Germany
	Date of manufacture
	Batch number













Symbol	Meaning
	Order/ article number (=ID)
	The manufacturer declares the conformity of the device with the applicable European Regulations and Directives.
	UK Conformity Assessed UK Representative: Obelis UK Ltd, Sandford Gate, East Point Business Park Oxford, OX4 6LB, United Kingdom Phone: +44 1865 910 145 E-Mail: info@obelis.co.uk
	Protect against moisture! Store in a dry place.
	This side up!
	Temperature limit during storage and transport
	Caution, fragile! Handle with care!
	Moisture limit during storage and transport (non-condensing)
	Air pressure limit
	Storage
	Transport
	QR code containing the following product details: <ul style="list-style-type: none"> - ID - LOT/batch number - country of origin - manufacturer address
	indication of positive flow direction
Made in Germany	information about country of origin
non-sterile	sensor is shipped in non-sterile condition
[...] L-VX.X	label revision/version

Table 3: Symbols on Single-Use Sensor and on Packaging

1.4 Definitions and Abbreviations

Definitions, Abbreviation	Meaning
BioProTT™ FlowSU System	multi-use flow meter (in combination with a single-use sensor) Please note: As the BioProTT™ FlowSU System can only carry out flow measurements when used in combination with the BioProTT™ FlowSU Sensor, the BioProTT™ FlowSU System refers to the combination of both components unless clearly stated otherwise.
BioProTT™ FlowSU Sensor	single-use sensor
multi-use part	BioProTT™ FlowSU System
sensor	BioProTT™ FlowSU Sensor
single-use part	BioProTT™ FlowSU Sensor
EMC	ElectroMagnetic Compatibility
N/A	Not Applicable
PoE	Power over Ethernet
PLC	Programmable Logic Controller
ID	I nner D iameter or I dentification (i.e. article number)
flow range	range from minimum to maximum flow
Qmin	Minimum flow
Qmax	Maximum flow
RSS	R eceived S ignal S trength which corresponds to the acoustic coupling
PoE	P ower o ver E thernet

Table 4: Definitions and Abbreviations

2 General Information



- Read this user manual carefully before installing and starting up the device!
 - This document describes the use of the BioProTT™ FlowSU System.
 - The user (= the person integrating the BioProTT™ FlowSU System into the application/ process) is responsible for any risks if it is not used and/or integrated correctly.
 - The customer must ensure that the persons involved in the integration of the BioProTT™ FlowSU System are adequately qualified in regard to the integration of industrial and process measurement transmitters.
 - In addition, the information in this user manual must be followed.
 - em-tec GmbH strongly advises against the use of the flow values provided by the BioProTT™ FlowSU System to serve as the basis to control a closed-loop system (also see [Usage Restrictions and Limitations](#))
 - If this is done, the risk must be fully analyzed and additional risk control measures have to be established.
 - It must be ensured that the grounding of the system the BioProTT™ FlowSU System and the BioProTT™ FlowSU Sensor are part of complies with installation standards.
 - Ensure that no particles or water enter the BioProTT™ FlowSU System or the USB port of either device at any time. Only plug in when dry.
 - Prior to each measurement, a zero flow adjustment must be carried out.
 - If the used BioProTT™ FlowSU Sensor is exchanged for another one during the application, another zero flow adjustment must be carried out before resuming the flow measurement.
 - The BioProTT™ FlowSU System and the BioProTT™ FlowSU Sensor form a sensitive sensor system. Electromagnetic fields or mechanic vibrations can lead to interferences affecting the measurements or the accurate function of the system.
 - The BioProTT™ FlowSU System consists of components sensitive to electrostatic discharge.
 - IT safety must be ensured by the user.
-

Although the BioProTT™ FlowSU System represents a state-of-the-art technology, the user may be put at risk if the device is operated incorrectly. You should therefore read this user manual carefully before use. In addition, inspect your equipment for completeness and damage when unpacking.

The user manual contains important information on the safe handling of the BioProTT™ FlowSU System and its components as well as its accessories. Read these instructions carefully before using the device and its accessories and keep them in an easily accessible location. Familiarize yourself with and observe all warning and safety information.

It is the responsibility of the operator of the device to ensure it is used, inspected, and maintained in accordance with the user manual. Subsequent revisions or instructions from the manufacturer must also be taken into account in this regard.

The manufacturer reserves the right to modify technical data without prior notice. Your local distributor will supply you with current information and updates to this document.

Please note:

- The BioProTT™ FlowSU System consists of
 - the multi-use holder with integrated electronic and namesake of the system, the BioProTT™ FlowSU System, which is mounted to the skid and
 - the single-use BioProTT™ FlowSU Sensor, which is inserted into the BioProTT™ FlowSU System
- The BioProTT™ FlowSU System and the BioProTT™ FlowSU Sensor must only be used in combination with each other.
- This user manual covers the features of software version V2.0.2.0 and, in parts, those of subsequent ones.
 - The exact software version on your device is displayed on the status information screen and/or can be accessed via the digital interface (see [chapter "Web Interface of the BioProTT™ FlowSU System"](#) for more information).

3 Intended Purpose and Restrictions

3.1 Intended Purpose

The BioProTT™ FlowSU System shall be used to measure the velocity of liquids and the detection of air-in-line in bioprocessing applications such as filtration, chromatography or other forms of fluid handling. Usually, the applications take place under strict hygienic conditions.

3.2 Usage Restrictions and Limitations

The BioProTT™ FlowSU System was developed and is sold for the above-mentioned intended purpose and use only. The BioProTT™ FlowSU System and the BioProTT™ FlowSU Sensor are not intended to be used for the following purposes/under the following circumstances:

- as medical device
- for measuring gaseous media or explosive and/or flammable liquids
- for measurements in explosive areas
- for legal metrology
- when the housing of the multi- and/or the single-use part is damaged

Due to its single-channel structure, the BioProTT™ FlowSU System is not a fail-safe system. If applied in safety-critical systems, the user has to consider a partial or complete system failure and is responsible for the introduction of additional risk measures to their system.

3.3 Liabilities and Responsibilities

It is the responsibility of the user to use, check and maintain the BioProTT™ FlowSU System and its components in accordance with this user manual. em-tec GmbH is neither liable nor responsible for any consequences arising from the use of the BioProTT™ FlowSU System and BioProTT™ FlowSU Sensor that does not comply with the operating and safety instructions or the specifications in this document.

3.4 Safety Instructions

The following safety instructions must be strictly observed and adhered to in order to ensure a safe handling of the BioProTT™ FlowSU System!

- The BioProTT™ FlowSU Sensor fulfills the requirements of USP Class VI standards and those of cleanroom class ISO 7.
 - To ensure that the single-use sensor continues to fulfill those requirements, it must be opened, installed, and handled under the respective conditions.
- Ensure that the BioProTT™ FlowSU Sensors are not contaminated in any way!
- If any part of the system or its accessories (cables, sensor, etc.) is damaged in any way, it must not be used.
- The BioProTT™ FlowSU System must not be immersed in liquids at any time and the connection ports must be kept dry.
 - To protect the connection port at the front, use the protective cap for when no sensor is connected (part of the scope of supply).
 - In the event of ingress of liquid into the device, immediately disconnect the power and stop using the device.
- The use of any accessories, cables, and sensors other than the specified ones is not permitted at any time.
- The BioProTT™ FlowSU System may be influenced by radio frequency (RF) devices. This includes mobile RF communication equipment. The use of a RF device in the vicinity of the BioProTT™ FlowSU System may therefore cause malfunctions of the components which, in turn, could lead to inaccurate or incorrect flow values.
- The device should not be covered or exposed to direct heat or sun.
- The device must not be opened. Any repairs must be carried out by em-tec GmbH or authorized service personnel only.
 - Unauthorized opening or repair means the warranty will be void.
- Neither the BioProTT™ FlowSU System nor the BioProTT™ FlowSU Sensor should come into contact with any chemicals other than those specified in chapter "[Cleaning and Disinfection of the BioProTT™ FlowSU System](#)".



3.5 Notice Concerning Compulsory Registration

Any major incidents in any ways connected to the product must be immediately reported to the manufacturer.

3.6 RoHS and REACH

Documentation regarding RoHS and REACH is available upon request.

3.7 Electrical Safety and Electromagnetic Compatibility

The BioProTT™ FlowSU System was tested according to **IEC 61326-1: 2022** (Emission: Class A, Group 1) and **IEC 61010-1: 2010/AMD1:2016** and **EN 61010-1:2010/AMD1:2019**.

Although the requirements of these standards were taken into account during the development and manufacturing, the user may be at risk if the system and/or any part thereof is used improperly.

Electrical Installation Requirements

Please follow the general safety information when installing the BioProTT™ FlowSU System. Please also observe any separate relevant safety and technical information of other electrical components used.

Electromagnetic Compatibility Requirements

The customer has to ensure that the relevant emission and immunity requirements of the device configuration are ensured in accordance with the required standards.

Interference of ultrasonic flow measurements by electromagnetic fields could be possibly identified by compromised measurement data, which is not related to the real flow.



It is important to ensure that the BioProTT™ FlowSU System is not placed near any disturbance source that is not compliant with the applicable standards since this could

- **influence and negatively affect the measurement.**
- **impact the data stored on the device and permanently corrupt it.**

3.8 Maintenance and Service

Service

The service for the BioProTT™ FlowSU System may only be carried out by em-tec GmbH.

If these instructions are not followed, em-tec GmbH shall accept no liability for the device and the warranty will be void.

If you experience any trouble with the measurement despite following the instructions in this user manual, or if your BioProTT™ FlowSU System is damaged in any way, please contact our service department.

Please note down the serial number before you contact our staff.

If you need to return the BioProTT™ FlowSU System for servicing, please follow these steps:

- Contact our service department at:
em-tec GmbH
Service Department
Am Graben 6-8
86923 Finning
Germany
em-tec-service@psgdover.com
- Our service department will send you a RMA form.
- Fill out the form and include it in the shipment.

Maintenance

Other than regularly cleaning the BioProTT™ FlowSU System and ensuring that there is no residue or dirt in the locking mechanism or connectors, there is no need for regular maintenance.

However, as we are continuously working on optimizing our products, there will be software updates available from time to time.

→ These updates can be carried out by the customer and are described in D143-705, which is available [for download](#) or upon request from [em-tec GmbH](#).

4 Description of the Measurement Principle

The function of the BioProTT™ FlowSU System is based on an acoustic measurement principle and utilizes the transit time method to determine the flow. For this, the system utilizes two ultrasonic piezo ceramics that each function as both transmitter and receiver for the burst of sound energy that is sent between them. For each transmission, the difference in transit time that it takes for the pulse to travel between the ceramics is measured. As the difference in transit time is directly related to the velocity of the liquid, it can be used as the basis to determine the volumetric flow rate.

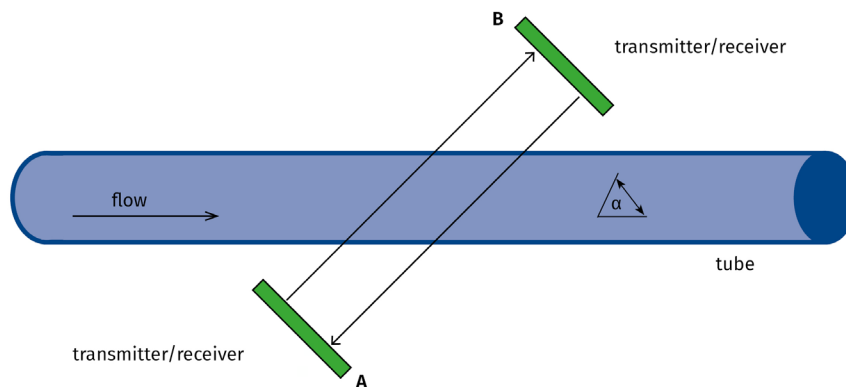

Figure 1: Sensor Structure

When sending ultrasonic signals through the measuring section, the transit time difference depends on the flow direction of the medium:

⇒ **The ultrasonic sound signals that are sent along the flow direction and volume flow of the medium, i.e. downstream, need less time to travel through the measurement section than the ultrasonic sound signals that are sent against the flow direction, i.e. upstream.**

The calculation of the flow rate is then carried out inside the BioProTT™ FlowSU System.

5 Scope of Supply

The **BioProTT™ FlowSU System** is shipped together with

- four screws of the type M5 x 12
- one drill plan
- one protection cap for the USB-C port

Please note:

To connect the BioProTT™ FlowSU System to your host system, a M12 to RJ 45 (D-coded) cable in Mode A is needed. Please refer to chapter 6.1 for a detailed PIN assignment.

The cable is **not included** in the scope of supply.

In addition to the cable, a **managed and galvanically isolated PoE Injector** (= Power over Ethernet) IEEE 802.3af Mode A with a voltage range of 36 V - 57 V is needed.

Please note:

The BioProTT™ FlowSU System (multi-use part) and the BioProTT™ FlowSU Sensor (single-use part) must be ordered separately; i.e. as two IDs and devices.

6 BioProTT™ FlowSU System Description



- Compliance with the prescribed operating parameters and safety information must be ensured prior to the use of the device.
- The user is responsible for the integration of the device into their system, including the observation of safety aspects and electromagnetic compatibility.

6.1 BioProTT™ FlowSU System

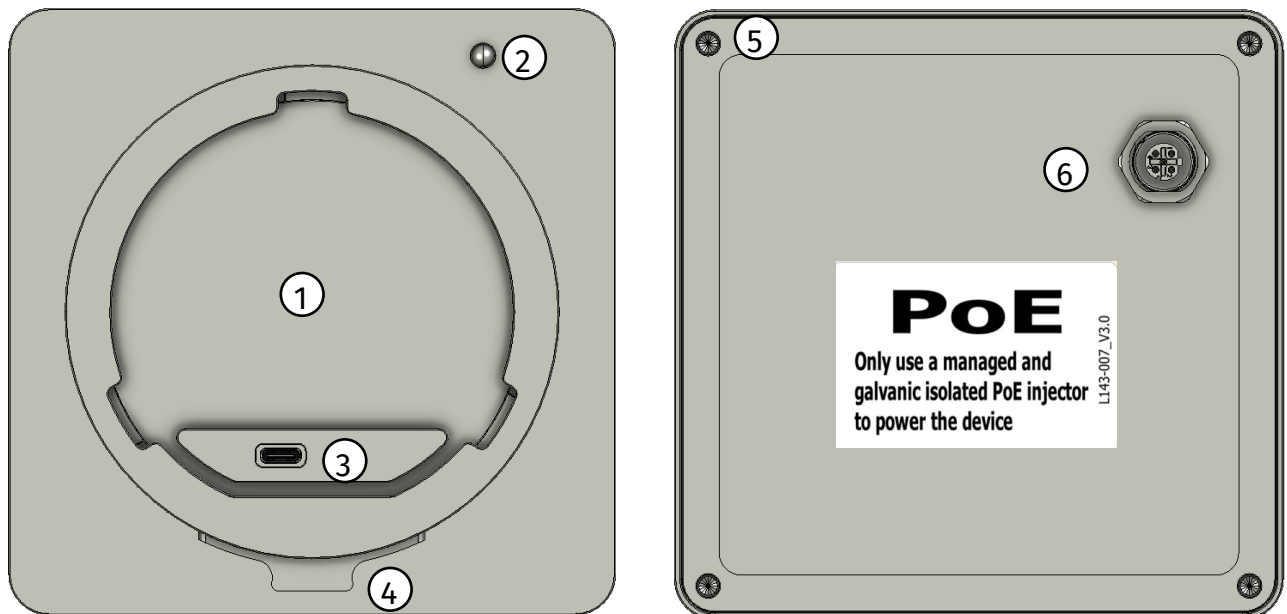

Figure 2: BioProTT™ FlowSU System Description

No.	Components	Description
1	sensor	<p>Space where the BioProTT™ FlowSU Sensor is placed</p> <p>Please note: When integrating the BioProTT™ FlowSU System into your skid, please be aware of the orientation of the BioProTT™ FlowSU System and how the BioProTT™ FlowSU Sensor is placed inside it; i.e. the LED (see number 2), should be at the top.</p>

No.	Components	Description																								
2	LED/ Status Indicator	<p>The LED communicates the following:</p> <ul style="list-style-type: none"> • green –continuous → device is powered → sensor is connected, recognized and the flow channel filled with liquid → no error present –flashing → device is powered → no sensor is connected → no error present <hr/> <ul style="list-style-type: none"> • blue –continuous → device is powered → sensor is connected and recognized but coupling is below 50 % → no error present –flashing → device is powered → sensor is connected and a bubble was detected → no error present <hr/> <ul style="list-style-type: none"> • red –continuous → device is powered → sensor is connected and recognized → error present –flashing → device is powered → sensor is connected → sensor is not recognized <p>Please note: The LED flashes as long as as the reason for it flashing is present.</p>																								
3	USB-C port	direct connection of the BioProTT™ FlowSU Sensor to the BioProTT™ FlowSU System																								
4	lock	lock to fix the BioProTT™ FlowSU Sensor to the BioProTT™ FlowSU System																								
5	screws	four M5 x 12 screws fixing the BioProTT™ FlowSU System to the skid																								
6	M12 connector	<p>M12 connector with managed and galvanically isolated PoE (= Power over Ethernet) Injector and Modbus TCP interface</p> <p>PIN assigment of necessary M12 to RJ 45 (D-coded) cable in 802.3af Mode A:</p> <table border="1"> <thead> <tr> <th colspan="2">M12</th> <th colspan="2">RJ45</th> </tr> <tr> <th></th> <th>PIN</th> <th>Colour</th> <th>PIN</th> </tr> </thead> <tbody> <tr> <td>TD+</td> <td>1</td> <td>Yellow</td> <td>1</td> </tr> <tr> <td>TD-</td> <td>3</td> <td>Orange</td> <td>2</td> </tr> <tr> <td>RD+</td> <td>2</td> <td>White</td> <td>3</td> </tr> <tr> <td>RD-</td> <td>4</td> <td>Blue</td> <td>6</td> </tr> </tbody> </table>	M12		RJ45			PIN	Colour	PIN	TD+	1	Yellow	1	TD-	3	Orange	2	RD+	2	White	3	RD-	4	Blue	6
M12		RJ45																								
	PIN	Colour	PIN																							
TD+	1	Yellow	1																							
TD-	3	Orange	2																							
RD+	2	White	3																							
RD-	4	Blue	6																							

Table 5: BioProTT™ FlowSU System Components

6.2 BioProTT™ FlowSU Sensor

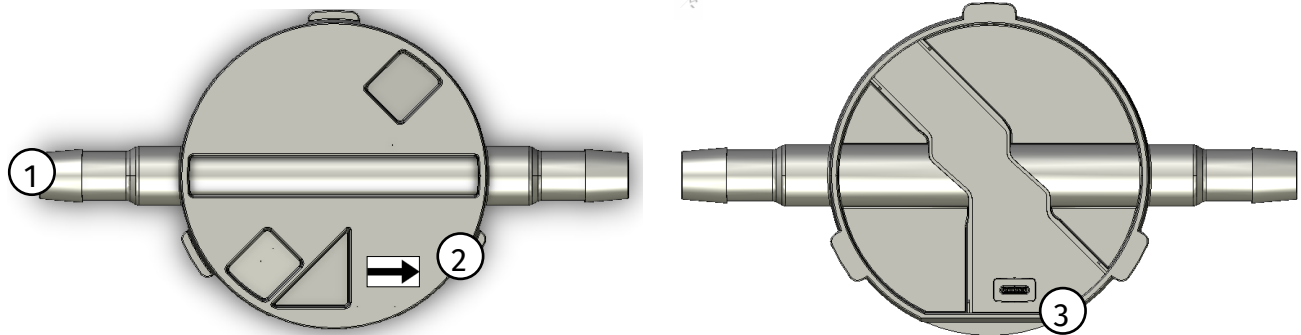

Figure 3: BioProTT™ FlowSU Sensor Description

No.	Component	Description
1	tube connection	connection from the tube to the BioProTT™ FlowSU Sensor Please note: Ensure that the tube is firmly attached to the sensor in order to stop it from slipping off. E.g. by securing it with cable ties, metall clamps, etc.
2	flow direction	label indicating the flow direction (i.e. from left to right) Please note: <ul style="list-style-type: none"> The BioProTT™ FlowSU Sensor can measure flows in both directions, i.e. from left to right as well as from right to left. When measuring against the indicated flow direction, i.e. from right to left, the flow values are displayed as negative values. → E.g. -350 ml/min instead of 350 ml/min. The accuracy is the same in both directions.
3	USB-C connector	connection from the BioProTT™ FlowSU Sensor to the BioProTT™ FlowSU System Please note: To stop the sensor from being damaged, ensure that it is lined up correctly before pushing it onto the USB-C connector; i.e. there is one protrusion at the top and two at the bottom of the sensor.

Table 6: BioProTT™ FlowSU Sensor Components

Please note:

The BioProTT™ FlowSU Sensor can be gamma-sterilized once with up to 50 kGy.

7 Installation and Setup of the BioProTT™ FlowSU System

7.1 Mounting of the BioProTT™ FlowSU System

As the BioProTT™ FlowSU System consists of a single- and a multi-use part, only the multi-use part, the BioProTT™ FlowSU System, is permanently fixed to your system. To do so, take the four screws included in the shipment and refer to the drill plan (which shows the front view):

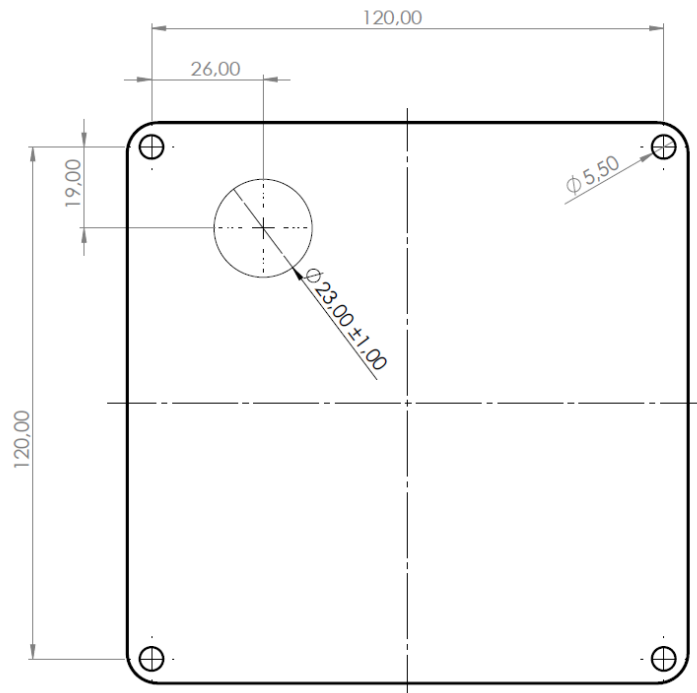

Figure 4: Drill plan for the BioProTT™ FlowSU System; front view

Please note:

- The dimensions indicated in the drill plan above reflect the actual size of the holes that need to be drilled.
- When mounting the BioProTT™ FlowSU System to your skid, ensure to use a torque of ≤ 6 Nm.
- The BioProTT™ FlowSU System should not be used as tube holder.
 - Tubes must be fixed in place with separate holders.
- When placing and aligning the BioProTT™ FlowSU System,
 - pay attention to the flow direction, your flow path and tube routing as the sensor can only be placed inside the evaluation device in one way, i.e. orientation.
 - Ideally, the in- and outlet section of the BioProTT™ FlowSU Sensor is straight for a distance of $15 \times \text{ID}$ (= inner diameter) of the sensor.
 - ensure it is not positioned on a drop line.
 - ensure it is in an upright position, i.e. the sensor, when attached, facing forward.

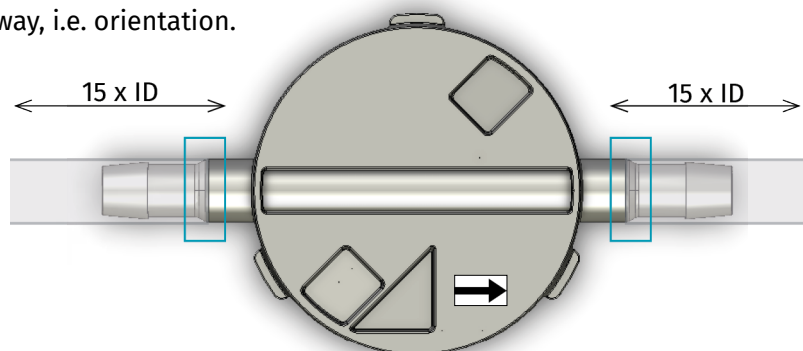
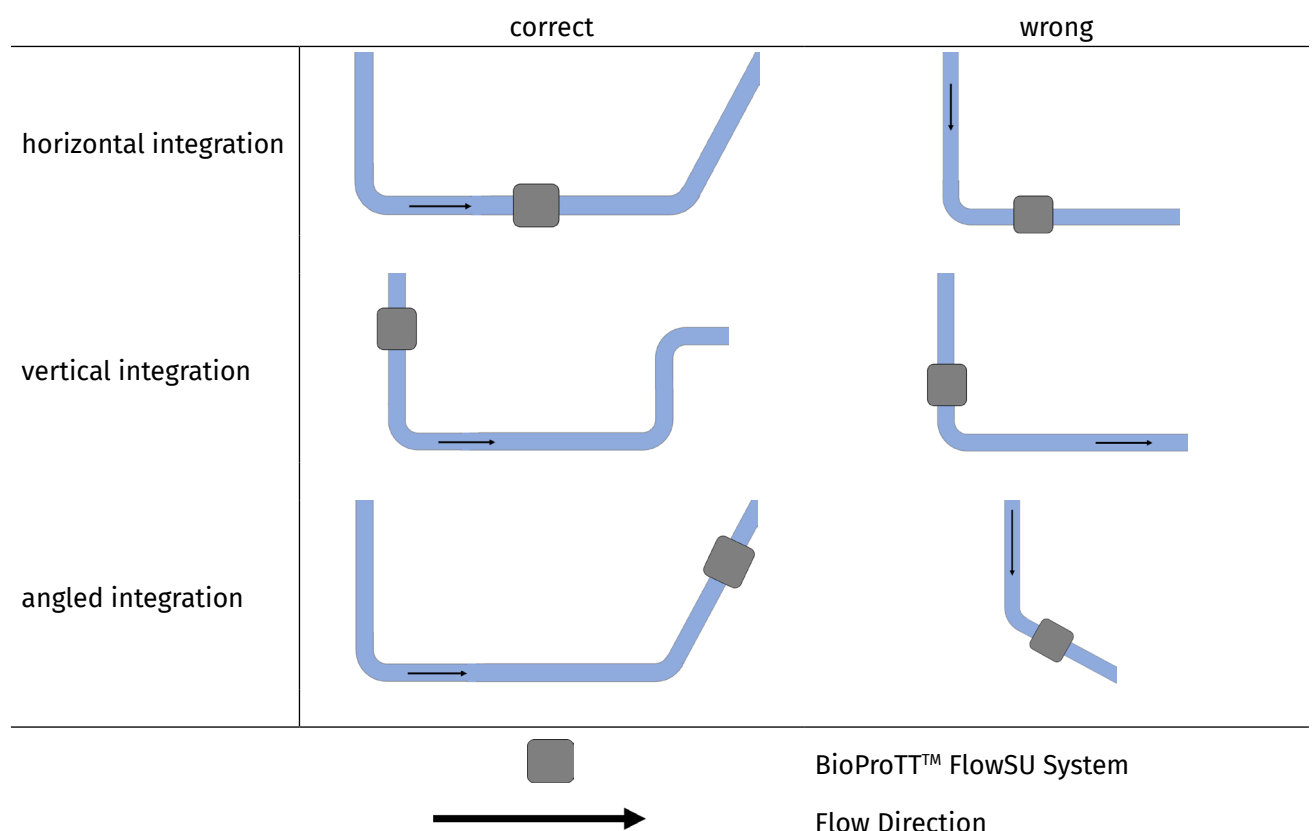

Figure 5: Ideal in- and outlet section of the BioProTT™ FlowSU Sensor

7.2 Installation Position of the BioProTT™ FlowSU System

When it comes to the installation position of the BioProTT™ FlowSU System on your skid, there are several things to keep in mind:

- Ideally, the tube section on either side of the BioProTT™ FlowSU Sensor is straight for a distance of 15 x ID (=inner diameter) of the tube.
- the BioProTT™ FlowSU System should ideally be placed in front of valves and/or pumps rather than after.
 - While a placement before the pump and/or valves is ideal, it is still important to ensure an adequate distance between them and the BioProTT™ FlowSU System to give the flow time to stabilize before entering the measurement section.
- If possible, try to avoid kinks and/or sharp angles in your flow path.



7.3 Connecting the BioProTT™ FlowSU System to the Host System

The BioProTT™ FlowSU System is connected to the host system and powered with a managed and galvanically isolated PoE (= Power over Ethernet; IEEE 802.3af Mode A) Injector using a M12 (D-coded) to RJ 45 cable in Mode A.

For more information on the Modbus TCP interface, please refer to chapter ["Modbus Interface"](#).

7.4 Unpacking and Installing the BioProTT™ FlowSU Sensor

7.4.1 Unpacking the BioProTT™ FlowSU Sensor

To unpack the BioProTT™ FlowSU Sensor, follow the steps listed below:

1. Open the outer bag to access the inner bag.
 - Carefully inspect the inner bag for damage.
2. Carefully open the inner bag and remove the BioProTT™ FlowSU Sensor.
 - Carefully inspect the BioProTT™ FlowSU Sensor for any damage.
 - If it is suspected that the sensor is damaged in any way, it must not be used.
3. Attach the tube by pushing it onto the tube connectors on either side of the sensor.
 - Make sure to take additional measures to stop the tube from detaching from the sensor; e.g. securing it with tube clamps, cable ties, etc.
4. Sterilize the sensor (and tube) according to your process and em-tec's requirements.*

***Please note:**

- The BioProTT™ FlowSU Sensor is shipped in non-sterile condition and must be sterilized by the customer according to their process and requirements as well as the requirements of em-tec.
- The BioProTT™ FlowSU Sensor can be gamma-sterilized once with up to 50 kGy.

7.4.2 Inserting the BioProTT™ FlowSU Sensor into the BioProTT™ FlowSU System

To insert the BioProTT™ FlowSU Sensor into the BioProTT™ FlowSU System, take off the cleaning cap, first, then follow the steps listed below:

1. Place the BioProTT™ FlowSU Sensor so its outline lines up with that of the BioProTT™ FlowSU System (see markings in the following image).



Do not use any force or press the BioProTT™ FlowSU Sensor onto the USB port as this could damage the USB connector.

→ When sliding the lock to the right, the sensor is automatically "pulled" back.

2. Once the sensor is inserted, slide the lock at the bottom to the right.
3. Once the lock is located to the right, the lock is closed and the sensor is fixed in place.

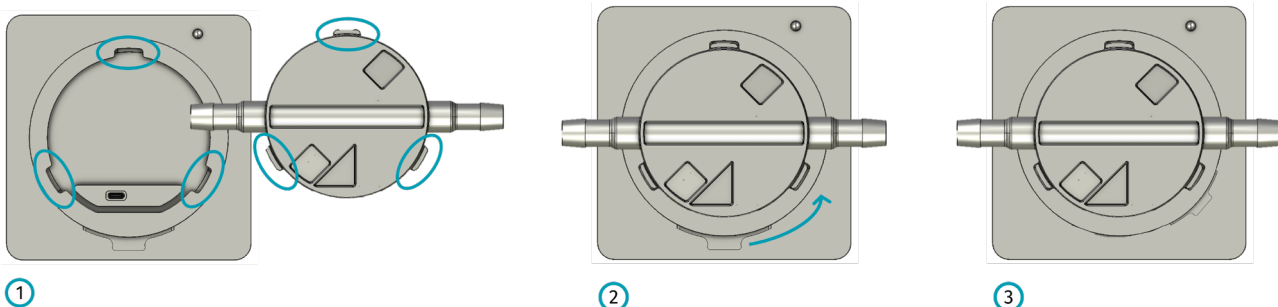

Figure 6: Inserting the BioProTT™ FlowSU Sensor into the BioProTT™ FlowSU System

Please remember to re-attach the cleaning cap to the BioProTT™ FlowSU System when taking off the BioProTT™ FlowSU Sensor.

7.4.3 Attaching the Tube to the BioProTT™ FlowSU Sensor

To attach the tube to the BioProTT™ FlowSU Sensor, proceed as follows:

1. Push the tube onto the tube connectors on either side.
 - The tube should fully cover the tube connectors and be pushed onto them as far as possible.
2. Fix the tube in place using, e.g. tube clamps or cable ties.

8 Initialization and Start-Up of the BioProTT™ FlowSU System

To initialize the BioProTT™ FlowSU System, connect the Ethernet cable to your host system or a PC for configuration.

Please note:

- The BioProTT™ FlowSU System is powered over Ethernet. The power is supplied by a PoE certified host system/device.
 - The default IP address of the device is 192.168.0.12 and can be changed by using the set-up menu on the web interface (also refer to chapter "[Set-Up and Configuration Page of the BioProTT™ FlowSU System](#)").
1. After initializing the BioProTT™ FlowSU System, connect it to the Modbus TCP environment, e.g. the PLC.
 2. Make sure to carry out a zero flow adjustment before starting the measurement.

Please note:

To zero the flow,

- the sensor must be completely filled with liquid.
- there must be no air bubbles within the sensor.
- the medium must not move.
 - If the offset is too big (>3,000 ml/min), e.g. when the pump is still running or the medium is not yet completely still, a zero flow adjustment is not possible.

Please also note:

As the function of the BioProTT™ FlowSU System and the BioProTT™ FlowSU Sensor is based on an ultrasonic measurement principle, the measurement is sensitive to temperature changes.

- To ensure the best possible accuracy, the measurement system should be given adequate time for the components to adapt to ambient and medium temperatures.
- Inadequate time to adapt to ambient temperatures might lead to an offset drift of measurement values.

9 Integration Information

9.1 Additional Uses of the BioProTT™ FlowSU System

Priming the Pump

When starting your process, it is possible to use the BioProTT™ FlowSU System for the priming of the flow path.

To do so,

- initialize the BioProTT™ FlowSU System and connect it to the Modbus TCP environment (see step 1. above)
- Connect the sensor (see chapter 6.3.2)
- Once everything is set up and the LED turns blue, turn on the pump.
 - the blue LED indicating
 - **no flow**
 - ⇒ **Flow is shown as 99999, which is not a valid value!**
 - **no coupling (i.e. the tube is not filled)**
- Wait until the LED turns from blue to green
 - the green LED indicating
 - **the device is powered**
 - **there is a sensor connected and recognized**
 - **there is no error present (i.e. the tube is completely filled)**
- The status changes (visible via the Modbus TCP interface and via the web interface), indicating that the tube is completely filled.
 - Also check for the bubble status (bit 11): If the bit remains "0", or 0_{hex} , for at least ten seconds, there are no bubbles present and the pump is fully primed.
- Now stop the pump.
- Once the liquid inside the tube has stopped moving, carry out a zero flow adjustment.
- Now your system is ready for measurement.

End of Process

Once your process is finished, you can tell that the tube/or the bag is empty by

- the LED turning blue again.
- the bit 4 and 5 being set to "1", or 10_{hex} and 20_{hex} respectively, indicating that the coupling is below 1 %.

9.2 Use of Status Information

While the status information is communicated via the Modbus TCP Interface and the web interface, it is, to some extent, also visible via the LED at the top right corner of the BioProTT™ FlowSU System (for more information, also see chapter "[Status Information Troubleshooting](#)").

9.2.1 Coupling Value

To ensure a smooth process and the safety of your product, em-tec strongly suggests using the status information and including it into the overall logic of your host system (for more information, also see chapter "[Status Information Troubleshooting](#)").

This is especially relevant for the coupling value (also referred to as RSS value; RSS =Received Signal Strength) as this is directly related to the flow values and their validity.

- **For instance, if the coupling value falls below 50 %, the indicated flow values might deviate greatly from the actual flow values and should therefore not be used.**
 - This is particularly the case when the flow values are used to control pumps, valves or other equipment within your process.
- **If the coupling value is below 1 %, i.e. there is no liquid in the flow channel of the sensor, both bit 4 and 5 are set to "1".**
 - In this case, the flow value is given out as 99999 by the system and consequently not valid.
 - This value must not be used.

Please note:

The coupling value is not explicitly given out via the Modbus TCP interface (here, it is output as 0 at all times; for more information also see chapter "[Read Input Register \(Function Code 0x04\)](#)").

- Instead, it is part of the status information.
- Consequently, the status information and its use must be programmed into the respective host system.

9.2.2 Bubble Detection

The BioProTT™ FlowSU System recognizes bubbles within the flow channel, i.e. within the line. The bubble is detected as soon as it enters the measurement section of the BioProTT™ FlowSU Sensor.

This triggers the following:

- **bit 11 switches from "0" to "1" and/or from 0_{hex} to 800_{hex}**
 - status information that a bubble is present
 - this information is visible via the Modbus TCP and the web interface
- **the LED on the BioProTT™ FlowSU System will flash blue for as long as the bubble is present within the measurement section.**

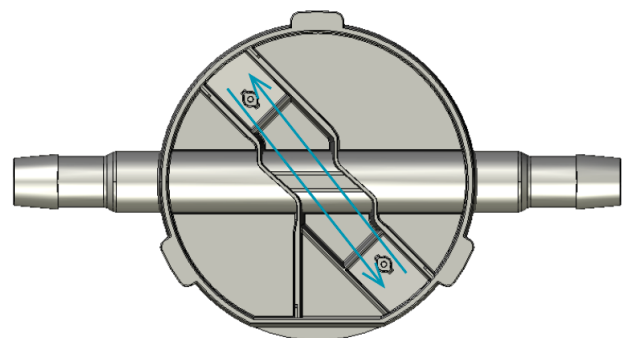

Figure 7: Measurement Section of the BioProTT™ FlowSU Sensor (in blue)

10 Web Interface of the BioProTT™ FlowSU System

The web interface can be used to set, adjust and configurate certain parameters. It also serves as a display.



- The web interface only serves as a display and must not be used for the flow measurement itself.
- It can take some time for the web interface to fully load.
- **Please note:** It is the responsibility of the user to ensure IT security. em-tec GmbH is not responsible for any errors or inconsistencies in the measurement that result from a lack of security.

After an update, or upon the first start, the **default IP address is 192.168.0.12**.

Please open this address in your web browser (Mozilla Firefox is preferred); the main page of the web interface will be open and show the information described in the following chapter.

10.1 Main Web Page for the BioProTT™ FlowSU System

The main page of the web interface of the BioProTT™ FlowSU System displays the following information:



BioProTT™ FlowSU System Information

The web interface only serves as a display and cannot be used for the flow measurement.

Device state **Online** (2)

Flow sensor (3)	Sensor (4)	Flow (ml/min) (5)	Error (6)	Status (7)	Status Ext. (8)	Zero (9)	Calib. Tbl (10)	(11)
Flow Sensor	Connected	-680	0	7010	0	Not zeroed	Table 2 v	Zero Undo Zero

Sensor Information (12)

Global Error for all Devices: 0000 (13)

Reset global Error (14)

Setup (15) Log Files (16)





Build: SW Ver: 00.00.00.03; SVN Rev: 312288; Build Date: 2023/03/16 10:38:59 (17)

www.em-tec.de (18)

Figure 8: Main web page of web interface of BioProTT™ FlowSU System

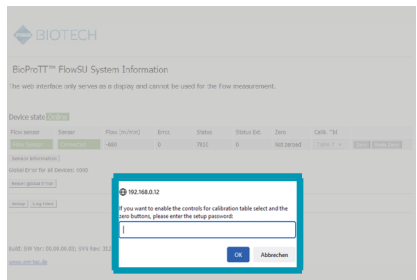
No.	Description
1	Link to open the main page of the web interface (page shown)
2	Device connection to a PC: <ul style="list-style-type: none"> • "green" and "online" indicating the BioProTT™ FlowSU System is connected to a PC • "gray" and "disconnected" indicating the BioProTT™ FlowSU System is not connected to a PC or that the data transfer between PC and BioProTT™ FlowSU System is not possible.

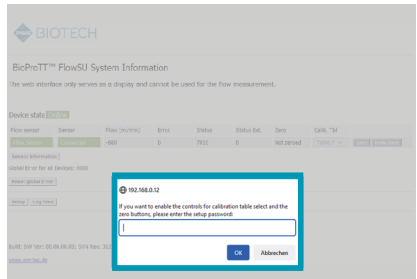

No.	Description	
3	Available BioProTT™ FlowSU Sensor <ul style="list-style-type: none"> "green" indicating the sensor is available "gray" indicating the sensor is not available 	
4	Connected Sensors: <ul style="list-style-type: none"> "green" indicating a sensor is connected "gray" indicating no sensor is connected 	
5	Flow value [ml/min] of the flow channel	
6	Error present on the flow channel (displayed as decimal value). For more information, refer to chapter " Troubleshooting ".	
7	Status of the BioProTT™ FlowSU Sensor (displayed as hexadecimal value). To receive additional information, move the mouse over the status information field and the current status will be displayed. For more information, refer to chapter " Troubleshooting ".	
8	Extended status of the BioProTT™ FlowSU Sensor (displayed as hexadecimal value). To receive additional information, move the mouse over the status information field and the current status will be displayed. For more information, refer to chapter " Troubleshooting ".	
9	Information if sensor was zeroed or not	
10	<p>Information about the selected sensor calibration table. In order to avoid unintentional changes of the calibration table, the user has to insert a password to proceed.</p> <p>To change the calibration table:</p> <ul style="list-style-type: none"> Select the drop-down menu. <ul style="list-style-type: none"> → This automatically opens a pop-up window asking for the password. The default password "uknown" <ul style="list-style-type: none"> → (Please note: like "unknown" but without the "n"). Once the password was inserted, the user can select "ok" to proceed, or "cancel" to stop the process and leave the calibration table unchanged. 	
	 <p>Some web browsers automatically save the user name and password, even if they do not explicitly let users know that they do. If this is the case, the pop-up window asking for the user name and password only appears once—for the first action where it is needed—but after that all actions can be carried out without the user having to enter the user name or password.</p>	
11	<p>Possibility to "zero" or to "undo zero" of the flow channel. Note: This is only possible if a sensor is connected.</p> <p>In order to avoid the flow being zeroed or the zeroing being undone unintentionally, the user has to insert a password to proceed.</p> <p>To "zero" or to "undo zero":</p> <ul style="list-style-type: none"> Select the field for the desired action. This automatically opens a pop-up window asking for the password. <ul style="list-style-type: none"> → The default password is "uknown" (<ul style="list-style-type: none"> ⇒ Please note, like "unknown" but without the "n". Once the password was inserted, the user can select "ok" to proceed, or "cancel" to stop the process. 	
	 <p>Some web browsers automatically save the user name and password, even if they do not explicitly let users know that they do. If this is the case, the pop-up window asking for the user name and password only appears once—for the first action where it is needed—but after that all actions can be carried out without the user having to enter the user name or password.</p>	
12	Possibility to open the sensor information page. For more information, refer to the description below.	
13	Global device error (displayed as hexadecimal value). For more information, refer to chapter " Troubleshooting ".	
14	Possibility to reset the global error.	

No.	Description
15	Possibility to open the set-up page. For more information, refer to the description below.
16	Possibility to open the device logging page. For more information, refer to the description below.
17	Software version of the BioProTT™ FlowSU System .
18	Link to the em-tec website

Table 5: Description of the main page of the web interface for the BioProTT™ FlowSU System

10.2 Sensor Information Page for the BioProTT™ FlowSU Sensor

The sensor information page displays the following information:

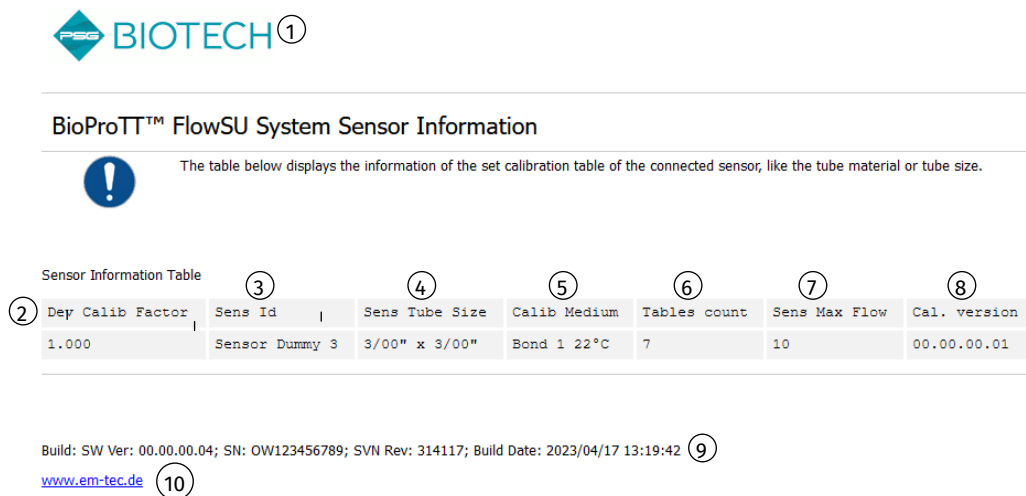

BioProTT™ FlowSU System Sensor Information

The table below displays the information of the set calibration table of the connected sensor, like the tube material or tube size.

Dep. Calib Factor	Sens Id	Sens Tube Size	Calib Medium	Tables count	Sens Max Flow	Cal. version
1.000	Sensor Dummy 3	3/00" x 3/00"	Bond 1 22°C	7	10	00.00.00.01

Build: SW Ver: 00.00.00.04; SN: OW123456789; SVN Rev: 314117; Build Date: 2023/04/17 13:19:42

www.em-tec.de

Figure 9: Sensor Information Page for the BioProTT™ FlowSU System

No.	Description
1	Link to open the main page of the web interface (page shown)
2	<p>Set calibration factor</p> <ul style="list-style-type: none"> The set calibration factor is independent of the restart/reconnect behavior and independent of the connected sensor. Please explicitly check the calibration factor when your medium or any of your process parameters have changed to ensure that set calibration factor is the correct one for your current application. <p>To set the calibration factor, refer to the setup page of the web interface. For more information on the calibration factor as such and on how to determine it, please contact em-tec GmbH.</p>
3	ID of the connected BioProTT™ FlowSU Sensor
4	Tube size stored for the used calibration table.
5	Medium stored for the used calibration table
6	Number of the currently set calibration table
7	Qmax of the connected sensor
8	EEPROM file version*
9	Software version of the BioProTT™ FlowSU System
10	Link to em-tec website

- * **Please note:**
 To integrate the BioProTT™ FlowSU System, the firmware and the file containing the parameter sets (also referred to as EEPROM file) must be updated first.
 The file version currently stored onto your BioProTT™ FlowSU System is indicated on the web interface.
 If, in the future, another update is needed, this is indicated here, too.

Sensor Information Table						
Dev Calib Factor	Sens Id	Sens Tube Size	Calib Medium	Tables count	Sens Max Flow	Cal. version
1.000	PLEASE	UPDATE	--- ---	1	0	00.00.00.01

Table 6: Description of the sensor information page of the BioProTT™ FlowSU System

10.3 Configuration Page of the BioProTT™ FlowSU System

The configuration page can be opened by clicking on the "setup" button on the main page.

- This opens a pop-up window.
- To log into the configuration page, enter the default user name "root" and the default password "uknown".
- ⇒ **Please note: like "uknown" but without the "n".**

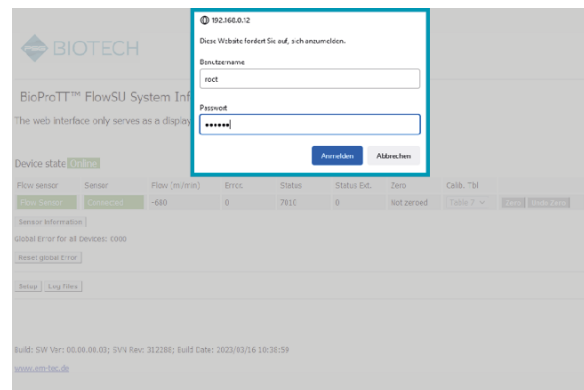

Figure 10: Log-In to the Setup Page



BioProTT™ FlowSU System Configuration

Network:

2	IP-Address:	192.168.0.12
3	Address Mask:	255.255.255.0
4	MODBUS Port number:	502

Miscellaneous:

5	Password:	••••••••
6	Device serial number:	179507
7	Device MAC address:	70-b3-d5-dd-11-b5
8	Bubble detection level:	Medium
9	Flow direction:	Positiv

	Flow Sensor	
10	Calibration Factor: (0.5 - 1.5)	1.000
11	MODBUS Flow Registers	Slow: 0,1 Hz; Fast: 1 Hz
12		Flow Sensor Adjustment



If a calibration factor has been entered for a specific flow sensor, please be aware that this factor has to be explicitly checked if e.g. a different table is selected on the same sensor.
Note: the set calibration factor is independent of the restart/reconnect behavior.



Previous settings will not be saved by the system. When changing the IP-Address, please review and note the set address before storing the setting. When the new IP-Address is stored, the device can only be connected under the new IP-Address.
Note: If the password or IP-Address are accidentally changed or lost, please contact em-tec GmbH.

13



In case of an error, the respective flow channel can be reset by pressing the reset button below. Before doing so, please check the system for failures, according to the troubleshooting in the FlowSU manual.

14





15

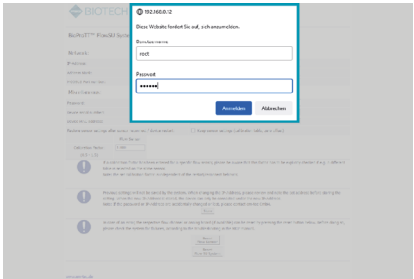

This action only resets the calibration data to the default values. Default settings are set during production or via default settings update files that are made available by em-tec. All custom calibration settings (e.g. all performed Onsite Adjustments) will be lost. General station settings are not impacted or changed by this action.

16

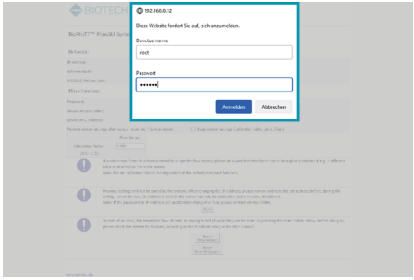
Figure 11: Setup and Configuration Page of the BioProTT™ FlowSU System

No.	Description
1	Link to open the main page of the web interface (page shown)
2	IP address
3	<p>Device IP-Address mask. The IP-Address mask can be changed by adding the new mask into this field and clicking the store* button.</p> <p>In order to avoid any unintentional changes of the IP address mask, the user has to enter a password to proceed.</p> <ul style="list-style-type: none"> Clicking into the field containing the address mask automatically opens a pop-up window. <ul style="list-style-type: none"> The default user name is "root". The default password is "unknown". <ul style="list-style-type: none"> Please note: like "unknown" but without the "n". To proceed with changing the IP address, select "ok", to stop the action and leave the IP address unchanged, select "Cancel". 
	 <p>Some web browsers automatically save the user name and password, even if they do not explicitly let users know that they do. If this is the case, the pop-up window asking for the user name and password only appears once—for the first action where it is needed—but after that all actions can be carried out without the user having to enter the user name or password.</p>
4	<p>Device Modbus-Port. The Modbus-Port can be changed by adding the new port into this field and clicking the store* button.</p> <p>In order to avoid any unintentional changes of the Modbus port, the user has to enter a password to proceed.</p> <ul style="list-style-type: none"> Clicking into the field containing the address mask automatically opens a pop-up window. <ul style="list-style-type: none"> The default user name is "root". The default password is "unknown". <ul style="list-style-type: none"> Please note: like "unknown" but without the "n". To proceed with changing the IP address, select "ok", to stop the action and leave the IP address unchanged, select "Cancel". 
	 <p>Some web browsers automatically save the user name and password, even if they do not explicitly let users know that they do. If this is the case, the pop-up window asking for the user name and password only appears once—for the first action where it is needed—but after that all actions can be carried out without the user having to enter the user name or password.</p>
5	<p>Password to open the setup page. The password can be changed by adding the new password into this field and clicking the store* button.</p>  <ul style="list-style-type: none"> If the field with the password stays unchanged, the password will NOT be changed. Only if the field with the password changes can the new password be changed to the device. The password change becomes active only after a re-start of the system.
6	Serial number of the BioProTT™ FlowSU System
7	MAC address of the BioProTT™ FlowSU System
8	<p>Here you can choose the sensitivity level of the bubble detection function depending on how sensitive your process and applications are to air in line.</p> <p>Available are the options</p> <ul style="list-style-type: none"> high medium low
9	<p>Option to set/inverse the flow direction.</p> <p>Please note: For the BioProTT™ FlowSU Sensors, the default flow direction is from right to left.</p> <ul style="list-style-type: none"> When the flow moves into the other direction, i.e. from left to right, the flow values are displayed as negative values. <ul style="list-style-type: none"> To display the values as positive despite the flow going from left to right, select "Positive". Should you prefer your flow values to be displayed as negative values despite the positive flow direction, you can, of course, also select "Negative".



No.	Description
10	<p>Possibility to set a calibration factor within the range of 0.5 to 1.5 in steps of 0.01.</p>  <ul style="list-style-type: none"> • The factor remains even after a power cycle or if another BioProTT™ FlowSU Sensor is connected. • If any of the application parameters change, ensure that the set factor is (still) the correct one.
11	<p>Option to set the averaging rate of the flow values.</p> <p>Please note that the averaging rate of the flow values is also relevant for the calculation of the totalizer.</p>
12	<p>Option to access the on-site adjustment page.</p> <p>For more information regarding the on-site adjustment, see chapter 13.1.</p>
13	<p>*Store button Clicking this button saves all performed changes on the set-up page.</p>  <ul style="list-style-type: none"> • Please note down the changed IP address, the changed IP address mask, the port and/or the changed password before clicking the store button. • Once the store button was pressed, the device can only be connected by using the new values. • If the set values are unknown, please contact the service department at em-tec GmbH.
14	<p>Possibility to reset the BioProTT™ FlowSU Sensor.</p> <p>Please note: When doing this, the sensor will not be "visible", i.e. offline, for the duration of the reset. .</p>
15	<p>Possibility to reset the BioProTT™ FlowSU System.</p> <p>This can be used when e.g. an error on a flow channel is present and if this error should be reset. Before clicking reset, check the error according to the information given in chapter "Troubleshooting".</p>
16	<p>Possibility to reset the the calibration tables of the BioProTT™ FlowSU System to the factory settings.</p> <p>To do so the sensor must be connected. When selecting the button, you will be asked for a user name and password:</p> <ul style="list-style-type: none"> - User Name: TableReseter - Password: Fa3cTo5ry2 <p>After confirming the user name and password, the LED will blink. ⇒ This means the reset was successful.</p> <p>Please note: This resets all calibration data to default values that were set during production or default settings updates. All customer-specific calibration data, i.e. on-site adjustments, will be lost. General settings are not impacted by this.</p>

Table 7: Description of the setup and configuration page of the BioProTT™ FlowSU System

10.4 Logging Page of the BioProTT™ FlowSU System



BioProTT™ FlowSU System Log Files



Below, all log-files created since the first device start are present. For each hour since the first device start, a separate log file is present if an event, warning or error occurred during that hour. For detailed information about the logging, please contact em-tec.

- ② • [49.log \(1233 B\)](#)
- [51.log \(132 B\)](#)
- [52.log \(189 B\)](#)
- [40.log \(824 B\)](#)
- [41.log \(40 B\)](#)
- [42.log \(2388 B\)](#)
- [43.log \(915 B\)](#)
- [45.log \(1313 B\)](#)
- [46.log \(1134 B\)](#)
- [47.log \(2663 B\)](#)

[First 10 Logfiles](#) |
 [Previous 10 Logfiles](#) |
 [Next 10 Logfiles](#) |
 [Last 10 Logfiles](#)

③

④

⑤

⑥

www.em-tec.de ⑦

Figure 12: Logging page of the BioProTT™ FlowSU System

No.	Description
1	Link to open the main page of the web interface
2	<p>Available log files of the BioProTT™ FlowSU System.</p> <p>For every hour the device is running, a new log file will be created as long as a logging was present.</p> <p>The log files are important for the service department of em-tec GmbH. If you contact our service department and are asked for the log files, they can be downloaded by clicking onto the relevant files. Once downloaded, the file can be sent to em-tec GmbH.</p> <p>Please note:</p> <ul style="list-style-type: none"> - While downloading the log files does not usually influence the flow measurement, we nevertheless advise against a download during the running process. - The log files are not sorted.
3	Possibility to switch to the first logging page containing 10 log files.
4	Possibility to switch to the previous logging page containing 10 log files.
5	Possibility to switch to the next logging page containing 10 log files.
6	Possibility to switch to the last logging page containing 10 log files.
7	Link to em-tec website

Table 8: Description of the logging page of the BioProTT™ FlowSU System

11 Modbus Interface

The following chapter indicates the supported Modbus functions and mapping of the internal registers to the Modbus registers/coils/inputs numbers.



Due to storage limitations, it is recommended to only query a maximum of 8 registers per request.

Please note that the register indexes that are not specified here are available, but do not contain any information.

11.1 Read Input Register (Function Code: 0x04)

Register Index	Register Name	Description	Parameter / Range
Flow Channel			
0	REG_RSS	16 bit word of coupling	This value is constantly output as 0. For information regarding the coupling value, please refer to the status information. For more information, refer to chapter " Status Information Troubleshooting " and chapter " Integration Information ".
1	REG_FLOW_SLOW_HI,	High 16 bit word of flow value averaged over the last 1s	-999999 ... +999999 (the actual Qmax depends on the connected sensor)
2	REG_FLOW_SLOW_LO,	Low 16 bit word of flow value averaged over the last 1s	
3	REG_FLOW_FAST_HI,	High 16 bit word of flow value averaged over the last 0.1s	-999999 ... +999999 (the actual Qmax depends on the connected sensor)
4	REG_FLOW_FAST_LO,	Low 16 bit word of flow value averaged over the last 0.1s	
5	REG_ERROR,	16 bit word of error code, as hexadecimal value	See chapter " Troubleshooting " for more information. 0x0000 means no error/warning
6	REG_R_TABLE,	16 bit word of current calibration table	1 ... 7
Device Information			
56	REG_IP_ADDR_1*	IP Address 1 (192.168.000.012)	0 .. 255
57	REG_IP_ADDR_2*	IP Address 2 (192.168.000.012)	0 .. 255
58	REG_IP_ADDR_3*	IP Address 3 (192.168.000.012)	0 .. 255
59	REG_IP_ADDR_4*	IP Address 4 (192.168.000.012)	0 .. 255
60	REG_IP_MASK_1*	IP Addr Mask 1 (255.255.255.000)	0 .. 255
61	REG_IP_MASK_2*	IP Addr Mask 2 (255.255.255.000)	0 .. 255
62	REG_IP_MASK_3*	IP Addr Mask 3 (255.255.255.000)	0 .. 255
63	REG_IP_MASK_4*	IP Addr Mask 4 (255.255.255.000)	0 .. 255
64	REG_IP_PORT_NUM	Port number 502	0 .. 65535

Table 9: Read input register

* Both the information regarding the IP address and the IP mask are too long for only one register, which is why it is divided into four registers, which, together, make up the respective address/information.

11.2 Additional Information Regarding the Read Input Register (Function Code: 0x04)

Register Index	Register Name	Description	Parameter / Range
65	REG_STATUS	16 bit word of status information, as bit-coded value	Contains different flags representing the status of the channel. For more information, see status list in chapter " Troubleshooting ".
73	REG_SENS_MAX_FLOW_HI	High 16 bit word of sensor max flow (Qmax)	-999999...+999999 (the actual Qmax depends on the connected sensor)
74	REG_SENS_MAX_FLOW_LO	High 16 bit word of sensor max flow (Qmax)	
89	REG_TABLE_COUNT	Amount of calibration tables on the sensor	1...7, depends on the connected sensor
97	REG_DEVICES_GLOBAL_ERROR	Global errors of the BioProTT™ FlowSU System, as hexadecimal value	Contains the global BioProTT™ FlowSU System device error. For more information, see chapter " Troubleshooting ". 0x0000 means no global error present
98	REG_SENS_SERIAL_HI	High 16 bit word of sensor serial number	This value is constantly output as 0 since the BioProTT™ FlowSU Sensors do not have individual serial numbers. It can therefore be disregarded.
99	REG_SENS_SERIAL_LO	Low 16 bit word of sensor serial number	
114	REG_STATUS_EXT	16 bit word of status information, as bit-coded value	Contains different flags representing the status of the channel. For more information, see status list in chapter " Troubleshooting ".
122	REG_CAL_FACT_HI	High 16 bit word of calibration factor set on channel 1 Please note: The calibration factor is shown as multiplied by 1000, i.e. a calibration factors of 1.0 is shown as 1000, 1.5 as 1500 and so on.	1...4294967295
123	REG_CAL_FACT_LO	Low 16 bit word of calibration factor set on channel 1 Please note: The calibration factor is shown as multiplied by 1000, i.e. a calibration factors of 1.0 is shown as 1000, 1.5 as 1500 and so on.	1...4294967295
138	REG_SW_VER_HI	High 32 bit value of the software version on channel 1. Please note: Each byte is a version position, i.e. aa.bb.cc.dd → 0xAABBCCDD → Example: 0x02030200 is version 02.03.02.00	0...999999

Register Index	Register Name	Description	Parameter / Range
139	REG_SW_VER_LO	Low 32 bit value of the software version on channel 1. Please note: Each byte is a version position, i.e. aa.bb.cc.dd → 0xAABBCCDD → Example: 0x02030200 is version 02.03.02.00	0...999999
154	REG_FPGA_VER_H	High 32 bit value of the FPGA version on channel 1. Please note: Each byte is a version position, i.e. aa.bb.cc.dd → 0xAABBCCDD → Example: 0x02030200 is version 02.03.02.00	0...999999
155	REG_FPGA_VER_LO	Low 32 bit value of the FPGA version on channel 1. Please note: Each byte is a version position, i.e. aa.bb.cc.dd → 0xAABBCCDD → Example: 0x02030200 is version 02.03.02.00	0...999999
Please note:	<p>The following registers are part of string values. This means that each register holds two chars in little endian format.</p> <p>→ regN + 0 LO = char 0 → regN + 1 LO = char 2 → etc. → regN + 0 HI = char 1 → regN + 1 HI = char 3</p> <p>For example: The serial number of a sensor is a string with the value "12345678". With this, registers 202 to 205 will have the following values:</p> <p>- Register 202: 0x3231 - Register 203: 0x3433 - Register 204: 0x3635 - Register 205: 0x3837</p>		
170	SENS_ID_BYTE	String bytes 0 and 1 of sensor ID	communicated as ASCII text
171	SENS_ID_BYTE	String bytes 2 and 3 of sensor ID	
172	SENS_ID_BYTE	String bytes 4 and 5 of sensor ID	
173	SENS_ID_BYTE	String bytes 6 and 7 of sensor ID	
174	SENS_ID_BYTE	String bytes 8 and 9 of sensor ID	
175	SENS_ID_BYTE	String bytes 10 and 11 of sensor ID	
176	SENS_ID_BYTE	String bytes 12 and 13 of sensor ID	
177	SENS_ID_BYTE	String bytes 14 and 15 of sensor ID	
202	SENS_SN_BYTE	String bytes 0 and 1 of sensor serial number	communicated as ASCII text
203	SENS_SN_BYTE	String bytes 2 and 3 of sensor serial number	
204	SENS_SN_BYTE	String bytes 4 and 5 of sensor serial number	
205	SENS_SN_BYTE	String bytes 6 and 7 of sensor serial number	

Register Index	Register Name	Description	Parameter / Range
218	SENS_TUBE_SIZE_BYTE	String bytes 0 and 1 of tube size suitable for sensor	communicated as ASCII text
219	SENS_TUBE_SIZE_BYTE	String bytes 2 and 3 of tube size suitable for sensor	
220	SENS_TUBE_SIZE_BYTE	String bytes 4 and 5 of tube size suitable for sensor	
221	SENS_TUBE_SIZE_BYTE	String bytes 6 and 7 of tube size suitable for sensor	
222	SENS_TUBE_SIZE_BYTE	String bytes 8 and 9 of tube size suitable for sensor	
223	SENS_TUBE_SIZE_BYTE	String bytes 10 and 11 of tube size suitable for sensor	
224	SENS_TUBE_SIZE_BYTE	String bytes 12 and 13 of tube size suitable for sensor	
225	SENS_TUBE_SIZE_BYTE	String bytes 14 and 15 of tube size suitable for sensor	
250	TUBE_MAT_BYTE	String bytes 0 and 1 of tube material calibrated for sensor	communicated as ASCII text
251	TUBE_MAT_BYTE	String bytes 2 and 3 of tube material calibrated for sensor	
252	TUBE_MAT_BYTE	String bytes 4 and 5 of tube material calibrated for sensor	
253	TUBE_MAT_BYTE	String bytes 6 and 7 of tube material calibrated for sensor	
266	SENS_MEDIUM_BYTE	String bytes 0 and 1 of medium calibrated for sensor	communicated as ASCII text
267	SENS_MEDIUM_BYTE	String bytes 2 and 3 of medium calibrated for sensor	
268	SENS_MEDIUM_BYTE	String bytes 4 and 5 of medium calibrated for sensor	
269	SENS_MEDIUM_BYTE	String bytes 6 and 7 of medium calibrated for sensor	
282	SENS_TEMP_BYTE	String bytes 0 and 1 of medium temperature calibrated for sensor	communicated as ASCII text
283	SENS_TEMP_BYTE	String bytes 2 and 3 of medium temperature calibrated for sensor	
284	SENS_TEMP_BYTE	String bytes 4 and 5 of medium temperature calibrated for sensor	
285	SENS_TEMP_BYTE	String bytes 6 and 7 of medium temperature calibrated for sensor	
298	TOTAL_VALUE_HI	High 16 bit word of totalizer value in ml.	-2147483647...2147483647
299	TOTAL_VALUE_LO	Low 16 bit word of totalizer value in ml.	-2147483647...2147483647
314	TOTAL_TIME_HI	High 16 bit word of totalizer timer in seconds	0...4294967294
315	TOTAL_TIME_LO	Low 16 bit word of totalizer timer in seconds	0...4294967294
330	TOTAL_TYPE	Average rate of flow value relevant for the totalizer calculation	0 = slow 1 = fast

Table 10: Additional Information

11.3 Read Discrete Inputs (Function Code: 0x02)

Register Index	Register Name	Description	Parameter / Range
Sensor Connect Information			
0	REG_SENS_CONNECT	connection state of sensor	0 = sensor disconnected 1 = sensor connected
Flow Channel Availability Information			
8	REG_DEV_AVAILABLE	channel availability	0 = channel is offline; i.e. no data can be received from this flow channel 1 = channel is online and data is received from it

Table 11: Read discrete inputs

11.4 Write Coil (Function Code: 0x05)

Register Index	Register Name	Description	Parameter / Range
Zero setting of flow sensor			
0	REG_W_ZERO	Set zero	1 = set zero 0 = unset zero Note: In order to carry out another zero flow adjustment, the bit must be reset to "0" first.
Reset Flow Channel			
8	REG_W_RESET	Reset	Set from 0 to 1 = reset flow channel. Note: In a failure situation on the flow channel such as a flow channel error, a failure can be reset by resetting the flow channel. Before doing so, check the device in regard to the reported error listed in chapter " Troubleshooting ". The bit must be reset from "1" to "0" before resuming the process.
Reset Global Error			
16	REG_W_RESET_GLOBAL_ERROR	Reset global error on device	Set from 0 to 1 = reset global error. Note: If a global error occurs on the device, it can be reset. Before doing so, check the device in regard to the reported error listed in chapter " Troubleshooting ". The bit must be reset from "1" to "0" before resuming the process.
Enabling and Disabling Totalizer Function			
17	REG_W_TOTALIZER_ENABLED	Enabling/Disabling of totalizer	0 = disabled 1 = enabled

Table 12: Write coil

Please note:

This is a bit register. Some PLCs only accept a bit-by-bit input; i.e., if several bits are set at once, it might happen that the PLC switches to another function code.

- As there is no other function code available for the BioProTT™ FlowSU System , if several bits are set at once, nothing happens.
- To ensure that the desired command is carried out, set the bits one by one.

11.5 Read Coil (Function Code: 0x01)

Register Index	Register Name	Description	Parameter / Range
Flow sensor zero information			
0	REG_R_ZERO	Set zero on channel	0 = zero is not set 1 = zero is set
8	REG_R_TOTALIZER_ENABLED	Totalizer enabled/disabled	0 = totalizer is disabled 1 = totalizer is enabled

Table 13: Read coil

11.6 Write Register (Function Code: 0x06)

Register Index	Register Name	Description	Parameter / Range
Set flow sensor calibration table			
0	REG_W_TABLE	Set calibration table, 1 indicates the first calibration table	1.. 7
17	REG_W_TOTALIZER TYPE	Set the average rate of the flow value, which is relevant for the totalizer calculation. Note: the average values for „slow“ and „fast“ can be set via the Web Interface (see no. 11 in Chapter "Configuration Page")	0 = slow 1 = fast

Table 14: Write register

Please note:

For performance reasons, it is recommended to bundle the reading of input registers per item as follows:

Flow channel:

(0 REG_RSS, 1 REG_FLOW_SLOW_HI, 2 REG_FLOW_SLOW_LO, 3 REG_FLOW_FAST_HI, 4 REG_FLOW_FAST_LO, 5 REG_ERROR, 6 REG_R_TABLE)

11.7 Read File Record Register (Function Code: 0x14)

Please note that for the Read File Record Registers, only one record per request read is supported. The length of the data to be read must correspond exactly to that listed here.

Register Index	Register Name	Description	Type of Output
Sensor ID			
0	REG_SENS_ID	16 byte word of sensor ID	communicated as ASCII text
Sensor Serial Number			
8	REG_SENS_SN	8 byte word of sensor serial number	communicated as ASCII text
Tube Size			
16	REG_SENS_SIZE	16 byte word of sensor size	communicated as ASCII text
Calibration Tube Material			
24	REG_TUBE_MAT	16 byte word of tube material the sensor on channel 1 is calibrated for. Please note: The tube material may be different for different calibration tables.	communicated as ASCII text

Register Index	Register Name	Description	Parameter / Range
Sensor Calibration Medium			
32	REG_SENS_CAL_MEDIUM	16 byte word of medium the sensor on channel 1 is calibrated for. Please note: The medium may be different for different calibration tables.	communicated as ASCII text
Sensor Calibration Temperature			
40	REG_SENS_CAL_TEMP	8 byte word of medium temperature the sensor is calibrated for. Please note: The temperature may be different for different calibration tables.	communicated as ASCII text

Table 15: Read File Record Register

12 Totalizer

The BioProTT™ FlowSU System includes, next to the flow measurement and bubble detection, also a totalizer function.

This function is accessible via the Modbus registers (see chapter [11.2](#), [11.4](#), [11.5](#), and [11.6](#) respectively) and values are indicated as milliliter.

The speed of the totalizer calculation, can be set via the Web Interface (see no. 11 in Chapter "Configuration Page"), where users can select between slow, moderate, and fast flow.



Please note that when the RSS value falls below 50% while the totalizer is running, these values, i.e. the values communicated while the RSS is below 50 %, are not taken into account during the calculation of the totalizer.

⇒ A low RSS value does not stop the totalizer.

⇒ For a correct and reliable totalizer calculation, a proper RSS value (i.e. above 50 %) is essential.

13 Calibration

The BioProTT™ FlowSU System is not individually calibrated but comes with a default calibration that works for and fits the parameters of the majority of biopharma applications. However, to ensure an even higher accuracy, it is possible to determine a calibration factor tailored to your specific application.

For more information regarding this process, you can access and download the respective TechNote on our [website](#).

13.1 Calibration Table

To allow the BioProTT™ FlowSU System to maintain its accuracy over the full temperature range, it comes with three different calibration tables that can be selected via the web interface (["Web Interface of the BioProTT™ FlowSU System"](#)) or the Modbus TCP interface (see chapter ["Write Register \(Function Code: 0x06\)"](#)) according to the the respective medium temperature.

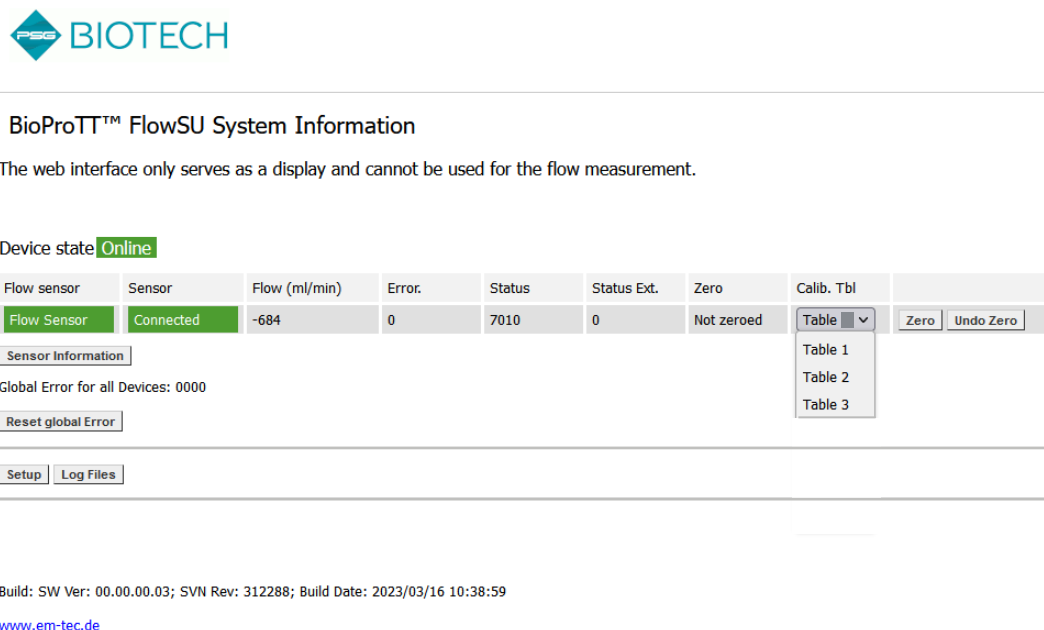

Figure 13: Web Interface Calibration Table Selection

The temperature ranges are defined as follows:

Table No.	Media Temperature
1*	21 °C

***Please note:**

- There will be additional calibration tables, i.e. additional temperatures, available in the future.
- If your applications uses different temperatures, you can, of course, carry out an on-site adjustment (see chapter 13) to ensure the accuracy of the flow measurement.

13.2 Calibration Factor

13.2.1 Determining the Calibration Factor

There are several options of how to determine an individual calibration factor, several of which are described in our TechNote "Determining the Calibration Factor", which is available [here](#).

13.2.2 Setting the Calibration Factor

Once determined, the calibration factor can be set on the web interface of the BioProTT™ FlowSU System (also refer to chapter "[Web Interface of the BioProTT™ FlowSU System](#)") and is consequently applied for every measurement.

The calibration factor can be adjusted in the range of 0.50 to 1.50 in steps of 0.01.

14 On-Site Adjustment & Factory Settings

14.1 On-Site Adjustment

Aside from setting a customer-specific calibration factor, it is also possible to carry out an on-site adjustment via the web interface.

During the on-site adjustment, a new regression line is created, meaning that each picosecond value is connected to a new, i.e. adjusted, flow value.

- This regression line replaces the original line that was based on default values only and represents the actual conditions and values of your application.
- See the following chapter for more information and for instructions on how to carry out the on-site adjustment.

This process is described in detail in D143-704 BioProTT™ FlowSU System On-Site Adjustment Guide, which is available upon request from em-tec GmbH or for [download](#) on our website.

14.2 Factory Settings

Factory settings contain the different calibration tables (see [chapter 13](#)). While the on-site adjustment carried out by the customers replaces the parameters previously used, i.e. the EEPROM file, factory settings are not impacted by that.

15 Cleaning and Disinfection of the BioProTT™ FlowSU System



- Make sure no detergents or disinfectants leak into this device.
- Make sure that the protection cap is attached to the USB port at the front before cleaning the device.

The BioProTT™ FlowSU System can be cleaned by wiping it with a damp, lint-free cloth and warm water. Before doing so, re-attach the cleaning cap the BioProTT™ FlowSU System is shipped with in order to protect the USB port.

1. To do so, align the cap and place it onto the BioProTT™ FlowSU System .
2. Slide the lock to the right in order to fix the cap in place.



Figure 14: Attaching the Protection Cap

For low-level disinfection, an aqueous 70 % isopropanol solution or Bacillo! can be used. Additionally, please follow the legal regulations valid in your country and the hygiene regulations for your specific application.



- The BioProTT™ FlowSU System may not be submerged into cleaning or disinfecting solution.
- The BioProTT™ FlowSU System is not suited for cleaning processes using machines.
→ Sterilization processes, especially steam sterilization or autoclaving, may not be used.
- Do not use cleaning agents that scratch or that are abrasive and/or corrosive (e.g. scouring powder!)
- Any connections must only be used when dry.
- Connectors must not be immersed in liquid.
- The concentrations and exposure times of the cleaning agents and disinfectants specified by the respective manufacturer must be strictly observed, including material compatibility.

The following surface disinfectant is recommended:

Name	Manufacturer	Contact
Bacillo!® AF	Hartmann	www.hartmann.de

Please note: Since the BioProTT™ FlowSU Sensor is a single-use product, there is no cleaning needed.

16 Troubleshooting

16.1 General Troubleshooting

If any issues occur with the BioProTT™ FlowSU System, try the following suggestions. If the problem persists, please contact your local distributor or em-tec GmbH directly.

The most common reason for an error/warning occurring is that the system has not been properly assembled. Ensure that the sensor and the cable connecting the BioProTT™ FlowSU System to the host system have been properly attached and that there are no electromagnetic interferences influencing the system.

Notes:

- If multiple errors/warnings are active simultaneously, only the error/warning that occurred first is reported.
- If a warning or error activates repeatedly, discontinue use and return the device for servicing.
- If a warning or error occurs that is not listed in the table below, please contact your local distributor or em-tec GmbH directly.

16.2 Errors and Warnings Originating from the Flow Measurement Board

These errors/warnings are sent via the Modbus TCP register and additionally displayed on the web interface of the device.

Problem/Possible Cause	Action
Error Codes: 10A_{hex} (266_{dec}) —start-up self-test on flow measurement board failed during memory checks	
Internal failure on flow measurement board (ROM-, RAM failure) during start-up was detected.	The BioProTT™ FlowSU System resets the board to clear the error*. → If the error is no longer present, then the device can be used like normal. → If the problem persists, return the device for servicing.
Problem/Possible Cause	Action
Error Codes: 103_{hex} (259_{dec}); 105_{hex} (261_{dec}); 106_{hex} (262_{dec}); 107_{hex} (263_{dec}); 10B_{hex} (267_{dec}) —start-up self-test on flow measurement board failed during flow measurement board voltage checks	
Internal voltage failure was detected on the flow measurement board during start-up.	Ensure the power supply for the BioProTT™ FlowSU System is within the specified operating range. The BioProTT™ FlowSU System resets the board to clear the error*. → If the error is no longer present, then the device can be used like normal. → If the problem persists, return the device for servicing.

Problem/Possible Cause	Action
Error Codes: 109_{hex} (265_{dec}) –start-up self-test on flow measurement board failed during flow measurement board temperature checks	
The temperature inside the device is too high.	Ensure the ambient temperature is within the specified operating range. If the temperature is too high, cool the device down. The BioProTT™ FlowSU System resets the board to clear the error*. → If the error is no longer present, then the device can be used like normal. → If the problem persists, return the device for servicing.
Error Codes: 202_{hex} (514_{dec}) –run-time self-test on flow measurement board failed during memory check	
Internal failure (ROM failure) during run-time.	The BioProTT™ FlowSU System resets the board to clear the error*. → If the error is no longer present, then the device can be used like normal. → If the problem persists, return the device for servicing.
Error Codes: 203_{hex} (515_{dec}); 204_{hex} (516_{dec}); 205_{hex} (517_{dec}); 206_{hex} (518_{dec}); 207_{hex} (519_{dec}); 20E_{hex} (526_{dec}) –run-time self-test on flow measurement board failed during flow measurement board voltage checks	
Internal voltage failure was detected on the flow measurement board during run-time mode.	Ensure the power supply for the BioProTT™FlowSU System is within the specified operating range. 1. Power off the device (disconnect the power supply) or perform a reset of the flow channel. 2. Power on the device again (reconnect the power supply). → If the error is no longer present, then the device can be used like normal. → If the problem persists, return the device for servicing.
Error Codes: 208_{hex} (520_{dec}) –run-time self-test on flow measurement board failed during flow measurement board temperature checks	
The temperature inside the device is too high.	Ensure the ambient temperature is within the specified operating range. If the temperature is too high, cool the device down. 1. Power off the device (disconnect the power supply) or perform a reset of the flow channel. 2. Power on the device again (reconnect the power supply). → If the error is no longer present, the device can be used like normal. → If the problem persists, return the device for servicing.

Problem/Possible Cause	Action
Error Codes: 209_{hex} (521_{dec}); 20A_{hex} (522_{dec}); 20B_{hex} (523_{dec}) –run-time self-test on flow measurement board failed during flow measurement board temperature, sensor, EEPROM, or RAM check	
A failure on the flow measurement board during run-time mode of the temperature sensor, EEPROM, or RAM was detected.	The BioProTT™ FlowSU System resets the board to clear the error*. → If the error is no longer present, then the device can be used like normal. → If the problem persists, return the device for servicing.
Error Codes: 20C_{hex} (524_{dec}); 20D_{hex} (525_{dec}) –run-time self-test on flow measurement board failed during check of the sensor calibration data	
The CRC of the internally stored sensor calibration data on the flow measurement board is not the same as the CRC value read from sensor calibration data.	Ensure the sensor is connected correctly to the BioProTT™ FlowSU System . The BioProTT™ FlowSU System resets the board to clear the error*. → If the error is no longer present, then the device can be used like normal. → If the problem persists, return the device for servicing.
Error Codes: 302_{hex} (770_{dec}); 303_{hex} (771_{dec}) –EEPROM read error	
EEPROM with calibration values could not be read correctly after the sensor was connected or after the BioProTT™ FlowSU System was started.	<ol style="list-style-type: none"> 1. Check if the sensor is connected properly to the BioProTT™ FlowSU System and ensure that the sensor is not damaged. 2. Check if there are not electromagnetic disturbances on the sensor cables (e.g. disturbances from a pump). 3. Disconnect the sensor. 4. Reconnect the sensor again. → If the error is no longer present, the device can be used like normal. → If the problem persists, return the device for servicing.
Error Codes: 401_{hex} (1025_{dec}) –signal processing FPGA test cycle failed	
During an internal signal processing test of the FPGA component on the flow measurement board, a failure was detected. Electromagnetic disturbances could lead to this failure situation.	The BioProTT™ FlowSU System resets the board to clear the error*. → If the error is no longer present, then the device can be used like normal. → If the problem persists, return the device for servicing.
Error Codes: 605_{hex} (1541_{dec}); 606_{hex} (1542_{dec}); 607_{hex} (1543_{dec}); 608_{hex} (1544_{dec}); 609_{hex} (1545_{dec}); 60A_{hex} (1546_{dec}); 60B_{hex} (1547_{dec}) –an internal CAN communication failure was detected on the flow measurement board	
On the internal CAN data communication of the flow measurement board(s) to the BioProTT™ FlowSU System main PCB, a failure was detected. The internal data communication has failed. Electromagnetic disturbances could lead to this failure situation.	The BioProTT™ FlowSU System resets the board to clear the error*. → If the error is no longer present, then the device can be used like normal. → If the problem persists, return the device for servicing.

Problem/Possible Cause	Action
Error Codes: 701_{hex} (1793_{dec}); 702_{hex} (1794_{dec}) –FPGA test on the flow measurement board failed during start-up	
During the start-up or after a flow channel reset, a failure on the flow measurement board FPGA was detected.	The BioProTT™ FlowSU System resets the board to clear the error*. → If the error is no longer present, then the device can be used like normal. → If the problem persists, return the device for servicing.
Error Codes: 703_{hex} (1795_{dec}); 704_{hex} (1796_{dec}); 705_{hex} (1797_{dec}); 801_{hex} (2049_{dec}); B02_{hex} (2818_{dec}); B03_{hex} (2819_{dec}); B04_{hex} (2820_{dec}); B08_{hex} (2821_{dec}) –internal failure on the flow measurement board was detected	
An internal failure was detected on the flow measurement board during the flow measurement.	The BioProTT™ FlowSU System resets the board to clear the error*. → If the error is no longer present, then the device can be used like normal. → If the problem persists, return the device for servicing.
Error Codes: C01_{hex} (3073_{dec}); C02_{hex} (3074_{dec}) –failure on a software task of the flow measurement board was detected	
Internal software task failure on the flow measurement board.	The BioProTT™ FlowSU System resets the board to clear the error*. → If the error is no longer present, then the device can be used like normal. → If the problem persists, return the device for servicing.
Error Codes: D01_{hex} (3329_{dec}) –internal database CRC or flow measurement board EEPROM communication failed	
The data transfer to or from the flow measurement board EEPROM (and therefore to the internal database) failed.	<ol style="list-style-type: none"> 1. Power off the device (disconnect the power supply) or perform a reset of the flow channel. 2. Power on the device again (reconnect the power supply). → If the error is no longer present, the device can be used like normal. → If the problem persists, return the device for servicing.
Error Codes: D02_{hex} (3330_{dec}) –minute counter failure	
Minute counter does not increase; i.e. has stopped.	The BioProTT™ FlowSU System resets the board to clear the error*. → If the error is no longer present, then the device can be used like normal. → If the problem persists, return the device for servicing.

Problem/Possible Cause	Action
Error Codes: D03_{hex} (3331_{dec}) –EEPROM storage failure	
The data transfer to the EEPROM failed after a changed entry in the database.	The BioProTT™ FlowSU System resets the board to clear the error*. → If the error is no longer present, then the device can be used like normal. → If the problem persists, return the device for servicing.
Error Codes: E02_{hex} (3586_{dec}) –task queue is full	
The internal task queue is full.	The BioProTT™ FlowSU System resets the board to clear the error*. → If the error is no longer present, then the device can be used like normal. → If the problem persists, return the device for servicing.
	<p>*An automatic resets usually takes about 30 seconds. During that time, the flow value that was measured directly before the reset is displayed.</p> <p>Please check the respective status code regarding the reset status of the BioProTT™ FlowSU System before, for example, using it to control the pump speed</p>

Table 16 Error and Warning originating from the BioProTT™ FlowSU System

16.3 Global Errors and Warnings Originating from the Flow Measurement Board

The most common reason for an error occurring is that the system has not been properly assembled. Ensure that the sensor and power supply cables have been properly attached and that there are no electromagnetic interferences influencing the system.

This global error is sent via the Modbus TCP register index 97 (see [chapter 9.2](#)) and additionally displayed on the web interface of the device.

Problem/Possible Cause	Action
Error Codes: 101_{hex} (257_{dec}) –a flow measurement board was unintentionally reset	
The flow measurement board was unintentionally reset, e.g. by an electromagnetic disturbance on the BioProTT™ FlowSU System or on the sensor.	For this error, there is no action required. The error can be reset via the web interface main page by clicking the "Reset Global Error" button. → If the error occurs frequently, return the device for servicing.
Error Codes: 102_{hex} (258_{dec}) –device communication failure	
The device does not communicate.	<ol style="list-style-type: none"> 1. Power off the device (i.e. disconnect the power supply) or reset it. 2. Power on the device again (i.e. reconnect the power supply). → If the error is no longer present, the device can be used like normal. → If the problem persists, return the device for servicing.
Error Codes: 104_{hex} (260_{dec}) –internal message counter is not increasing	
The message counter does not increase; i.e. has stopped.	<ol style="list-style-type: none"> 1. Power off the device (i.e. disconnect the power supply) or reset it. 2. Power on the device again (i.e. reconnect the power supply). → If the error is no longer present, the device can be used like normal. → If the problem persists, return the device for servicing.
Error Codes: 108_{hex} (264_{dec}) –EEPROM CRC failure	
The data transfer to or from the EEPROM has failed.	<ol style="list-style-type: none"> 1. Power off the device (i.e. disconnect the power supply) or reset it. 2. Power on the device again (i.e. reconnect the power supply). → If the error is no longer present, the device can be used like normal. → If the problem persists, return the device for servicing.

Problem/Possible Cause	Action
Error Codes: 301_{hex} (769_{dec}) —communication failure between the flow measurement board and the main board of the BioProTT™ FlowSU System .	
A failure was detected on the internal device communication between the flow measurement board and the main board of the BioProTT™ FlowSU System .	The BioProTT™ FlowSU System resets the board to clear the error. → If the error is no longer present, then the device can be used like normal. → If the problem persists, return the device for servicing.
Error Codes: 1080_{hex} (4224_{dec}) —supply voltage is out of range	
The supply voltage is out of range.	Ensure the supply voltage is within the specified operating range. The BioProTT™ FlowSU System automatically resets the board to clear the error. → If the error is no longer present, the device can be used like normal. → If the problem persists, return the device for servicing.
Error Codes: 2080_{hex} (8320_{dec}) —supply voltage is out of range	
The supply voltage is out of range.	Ensure the supply voltage is within the specified operating range. The BioProTT™ FlowSU System automatically resets the board to clear the error. → If the error is no longer present, the device can be used like normal. → If the problem persists, return the device for servicing.
Error Codes: 4080_{hex} (16512_{dec}) —supply voltage is out of range	
The supply voltage is out of range.	Ensure the supply voltage is within the specified operating range. The BioProTT™ FlowSU System automatically resets the board to clear the error. → If the error is no longer present, the device can be used like normal. → If the problem persists, return the device for servicing.

Problem/Possible Cause	Action
Error Codes: 8080_{hex} (32896_{dec}) –failure of EEPROM, SD card, or EEPROM file	
The EEPROM inside the BioProTT™ FlowSU System could not be read correctly.	<ol style="list-style-type: none"> 1. Check if the BioProTT™ FlowSU Sensor is connected properly to the BioProTT™ FlowSU System and ensure that neither the multi-use nor the single-use part of the system is damaged. 2. Check if there are any electromagnetic disturbances present that might influence the system. 3. Disconnect the BioProTT™ FlowSU Sensor. 4. Reconnect the BioProTT™ FlowSU Sensor. <p>→ If the error is no longer present, the device can be used like normal.</p> <p>→ If the problem persists, return the device (multi-use part) for servicing.</p>

Table 17: Global Errors and Warnings

16.4 Other Troubleshooting

The most common reason for an error/warning occurring is that the system has not been properly assembled. Ensure that the sensor and power supply cables have been properly attached and that there are no electromagnetic interferences influencing the system.

Problem/Possible cause	Action
Power LED off	
Power not connected; voltage/current of power supply too low	Check if the power supply is connected and delivers +36 V to +57 V.
Defect of internal fuse of device	Return the device for servicing.
Device LED flashing green	
No BioProTT™ FlowSU Sensor is connected.	Connect a BioProTT™ FlowSU Sensor to the BioProTT™ FlowSU System (see chapter " Installation and Setup of the BioProTT™ FlowSU System ").
Device LED is continuously blue	
The coupling of the BioProTT™ FlowSU Sensor is below 50 %.	Ensure that the tube is completely filled with liquid and that there are no bubbles present.
Device LED flashing blue	
A bubble was detected.	Take the relevant measures defined in your process for when there is air in line.
Device LED is continuously red	
There is an error present.	Check via web interface or Modbus TCP interface if there is an error or warning present and refer to the troubleshooting in the previous chapters.
Device LED is flashing red	
An BioProTT™ FlowSU Sensor size is not recognized.	Please exchange the BioProTT™ FlowSU Sensor for a new one or update the EEPROM file (see chapter " Sensor Information Page " for more information).

Problem/Possible cause	Action
Flow reading not in the specified range	
A wrong calibration factor is set of a flow channel	Check on the device web server or the Modbus TCP interface if the calibration factor is set correctly (refer to chapter " Sensor Information Page for the BioProTT™ FlowSU Sensor ").
Calibration table selection or zero setting lost after power cycle or flow channel reset	
Keep sensor settings function is not set.	Check on the device web server if the "keep sensor settings" are set correctly (refer to chapter " Setup and Configuration Page of the BioProTT™ Flow SU System ").
Sensor is sometimes not recognized or flow channel resets sometimes	
Electromagnetic disturbances affect the sensor connection or flow measurement boards	<ol style="list-style-type: none"> 1. Check if e.g. cables with high noise emission (e.g. cables from a motor driver such as a frequency converter to a motor) are separated from the sensor extension cables. 2. Ensure that the BioProTT™ FlowSU System, the extension cables and the sensors are located far away from electromagnetic noise sources. <p>If the problem persists, return the device for servicing.</p>
Zero flow adjustment is not possible	
Flow offset is bigger than 3,000 ml/min.	<ol style="list-style-type: none"> 1. Check if the pump is turned off and that there is no flow within the system. 2. Check if the sensor is damaged in any way. <p>If the flow offset remains despite the pump being stopped, please contact em-tec GmbH.</p>

Table 18: Other troubleshooting

16.5 Status Information Troubleshooting

The status information of the flow channels contains information regarding the channels' conditions such as additional information about the connected sensor. The status is displayed on the web interface and on the Modbus TCP interface as hexadecimal value in form of a 16 bit word (2 byte).



When the status information is used for the integration of the BioProTT™ FlowSU System into an industrial system, please contact em-tec GmbH for more detailed information in regard to the integration.

The status information looks as follows:

Bit No.	When bit is "0"	Status as hexadecimal value	When bit is "1"	Status as hexadecimal value
0	Measurement is running	0 _{hex}	Measurement was stopped	1 _{hex}
1	Sensor was entirely loaded*		Sensor not (yet) entirely loaded*	2 _{hex}
2	A sensor is connected		No sensor connected*	4 _{hex}
3	Temperature is ok Flow measurement board temperature <65°C		Temperature warning Flow measurement board temperature >70°C	8 _{hex}
4	The coupling (RSS) is ok**.		The coupling (RSS) is below 50 %***	10 _{hex}
5	The coupling (RSS) is ok**		No coupling (RSS); i.e. below 1 %***	20 _{hex}
6	-		-	40 _{hex}
7	-		-	80 _{hex}
8	Offset correction is possible		Offset correction is not possible (flow too high/depends on connected sensor)	100 _{hex}
9	-		-	200 _{hex}
10	Sensor was not zeroed.		Sensor was zeroed or sensor is known and was zeroed before*	400 _{hex}
11	No bubble present		Bubble detected	800 _{hex}
12	Together, bit 12, 13, and 14 describe the currently selected calibration table:			1000 _{hex}
13	<ul style="list-style-type: none"> - 000 = calibration table 1 - 100 = calibration table 2 - 010 = calibration table 2 - 110 = calibration table 3 - 001 = calibration table 4 - 101 = calibration table 5 - 011 = calibration table 6 - 111 = calibration table 7 			2000 _{hex}
14				4000 _{hex}
15	Power-On flag on the flow measurement was reset by the BioProTT™ FlowSU System	0 _{hex}	Power-On flag on the flow measurement board was not yet reset by the BioProTT™ FlowSU System ****	8000 _{hex}

*) This status information is also present in the Modbus TCP registers.

**)

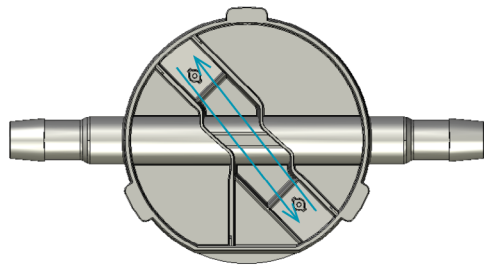

Each sensor contains two piezo ceramics that send and receive ultrasonic sound signals. The signal is always send diagonally, each cermamic acting as both sender and receiver, resulting in a measurement section inside the sensor.

Measurement Section

***) Please note that when these bits are set, the displayed flow values are not valid.

****) This flag is used internally in the BioProTT™ FlowSU System to detect inadvertent resets of the flow measurement board.

Table 19: Status Information Troubleshooting

The extended status information contains the following information:

Bit No.	When bit is "0"	Status as hexadecimal value	When bit is "1"	Status as hexadecimal value
0	The flow measurement board is not reset.	0 _{hex}	The flow measurement board is reset.	1 _{hex}
1	Coupling and viscosity are ok.		Coupling and/or viscosity is out of range.	2 _{hex}

Table 20: Extended Status Information Troubleshooting

A possible status information could look like the following:

8007 _{hex} (1000 0000 0000 0111 _{bin} .)	
Bit 0 = 1	Measurement was stopped
Bit 1 = 1	Sensor not (yet) loaded
Bit 2 = 1	No sensor connected
Bit 15 = 1	Power-On flag on flow measurement board is 1*
No sensor is connected	

For your process, status and LED mean the following:

Status	LED	Description	Meaning for/ Impact on Process
bit 2 set to "1"/4 _{hex}	flashing green	no sensor connected	There is either no sensor connected or it is not recognized. Please note: This can also happen if the the sensor EEPROM file has not been updated, yet, so the BioProTT™ System has no data to access for the respective sensor.
bit 4 (and 5) are set to "1"/10 _{hex} (and 20 _{hex})	blue	RSS value is below 50 %	<ul style="list-style-type: none"> The sensor/tubing system is not fully filled with liquid. The displayed flow values might not be valid and deviate from the real flow within the system.
bit 11 set to "1"/ 800 _{hex}	flashing blue	bubble detected	There is air within the tubing system
not indicated as status but as error	red	error is present	Check Modbus TCP or web interface for detailed error code.

Status	LED	Description	Meaning for/ Impact on Process
bit 2 set to "1"/ 4 _{hex}	flashing red	The connected sensor is not recognized	The connected sensor is not recognized. Please note: This can also happen if the the sensor EEPROM file has not been updated, yet, so the BioProTT™ System has no data to access for the respective sensor.
bit 8 set to "1"/ 100 _{hex}	n/a	offset correction or zero flow adjustment is not possible	Flow is too high for a zero flow adjustment to be carried out. For a zero flow adjustment, the liquid inside the tube must not move, i.e. there must be no flow present. Please note: A zero flow adjustment is essential before every new measurement and imperative when it comes to maintaining the accuracy of the flow measurement system.

Table 21: Impact of Status on LED and Process

17 Environmental Protection and Disposal

Disposal

The BioProTT™ FlowSU System and any accessories must be disposed of in accordance with the applicable national provisions for electronic components and in accordance with the requirements of EU Directive **2012/65/EC** Waste Electrical and Electronic Equipment (WEEE).

The em-tec GmbH WEEE registration number is: **DE 99135207**.

Upon receipt, we repair or dispose of these components properly. For our address please see the very beginning of this user manual. For the best utilization of raw materials, the product and its components and accessories should not be disposed of together with household waste. All parts must be collected separately from household waste and disposed of in an environmentally responsible way in accordance to local regulations.

- Before disposal, decontaminate all parts according to the applicable procedure.
- If you have questions about disposal, please contact em-tec GmbH's service department.
- Waste may only be brought to the appropriate recycling facility if there is no risk of potential infection from electrical and electronic waste.

18 Contact Information for Technical Support

Technical support is provided by:

em-tec GmbH

Am Graben 6-8

86923 Finning

Germany

e-mail: em-tec-info@psgdover.com

phone: +49 8806 9236 0

fax: +49 8806 9236 50

For returns/RMAs or service support, please contact: em-tec-service@psgdover.com

19 Technical Specifications of the BioProTT™ FlowSU System

19.1 BioProTT™ FlowSU System

Size (HxWxD), weight

135 x 135 x 45 mm ± 5 mm, approx. 1500 g
stainless steel

Housing material

(316L; material no. 1.4404 (X2CrNiMo17-12- 2))

Surface Roughness

Rz =10

IP-Code

IP65 (=UL 50E Type 2):

in mated and mounted condition;

i.e. when protection cap or sensor is attached and when mounted to the skid.

IP20: in unmated and/or dismounted condition; i.e.

when protection cap or sensor is not attached and/or when not mounted to the skid.

Power supply

Power over Ethernet

(IEEE 802.3af; voltage range 36 V - 57 V)

Sensor Connection

USB-C port

Expected Product Life

5 years

Interface

Modbus TCP (RJ-45 connector)

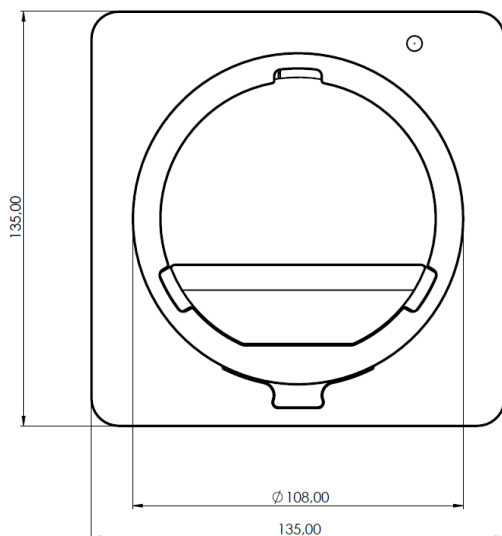

Figure 15: BioProTT™ FlowSU System — Technical Drawing: Front

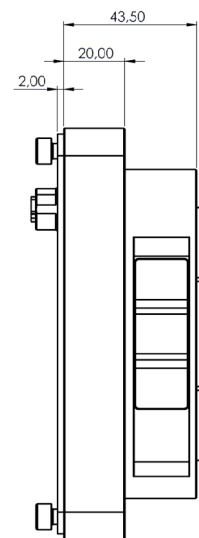

Figure 16: BioProTT™ FlowSU System — Technical Drawing: Side

Ambient Conditions

Air Pressure

70 kPa to 106 kPa

Operating Altitude

up to 2000 m (6600 feet)

Operating temperature range

10 °C to 40 °C (50 °F to 104 ° F)

Storage temperature range

-20 °C to 45 °C (-4 °F to 113 ° F)

Transport temperature range

-20 °C to 55 °C (-4 °F to 131 ° F)

Relative Humidity (Transport, Storage, Operation)

10 % to 96 % (non-condensing)

EMC

To be ensured by customer

19.2 BioProTT™ FlowSU Sensor

Size (i.e. inner diameter); Dimensions (HxWxD); Weight	<ul style="list-style-type: none"> – 1/4"; 135 x 90 x 33 mm; ± 2 mm; 85 g – 3/8"; 137 x 90 x 34 mm; ± 2 mm; 89 g – 1/2"; 172 x 90 x 37 mm; ± 2 mm; 100 g – 3/4"; 180 x 90 x 45 mm; ± 2 mm; 127 g – 1" ; 190 x 90 x 49 mm; ± 2 mm; 147 g
Housing material	Lexan Grade HPH4404
Degree of pollution	2
Classification of wetted parts*	USP Class VI, free of animal derived components and TSE/BSE
Surface in Contact with the Product:	<ul style="list-style-type: none"> – 1/4": approx. 22 cm² – 3/8": approx. 35 cm² – 1/2": approx. 62 cm² – 3/4": approx. 97 cm² – 1" : approx. 151 cm²
Cleanroom Conditions *	ISO Class 7; wetted part packaging according to USP <661>
Sterilization	gamma sterilizable once with up to 50 kGy
IP-Code	IP65 (=UL 50E Type 2): in mated condition; i.e. when inserted in the BioProTT™ FlowSU System IP20: in unmated condition; i.e. when not inserted in the BioProTT™ FlowSU System
Power supply	powered by the BioProTT™ FlowSU System
Connection to BioProTT™ FlowSU System	USB-C connector
Expected Shelf Life	24 months after gamma sterilization
Duration of Use	60 days
Medium Temperature	4° C to 60° C

* For more information regarding standards and certifications, please see the Qualification Handbook in the Annex.

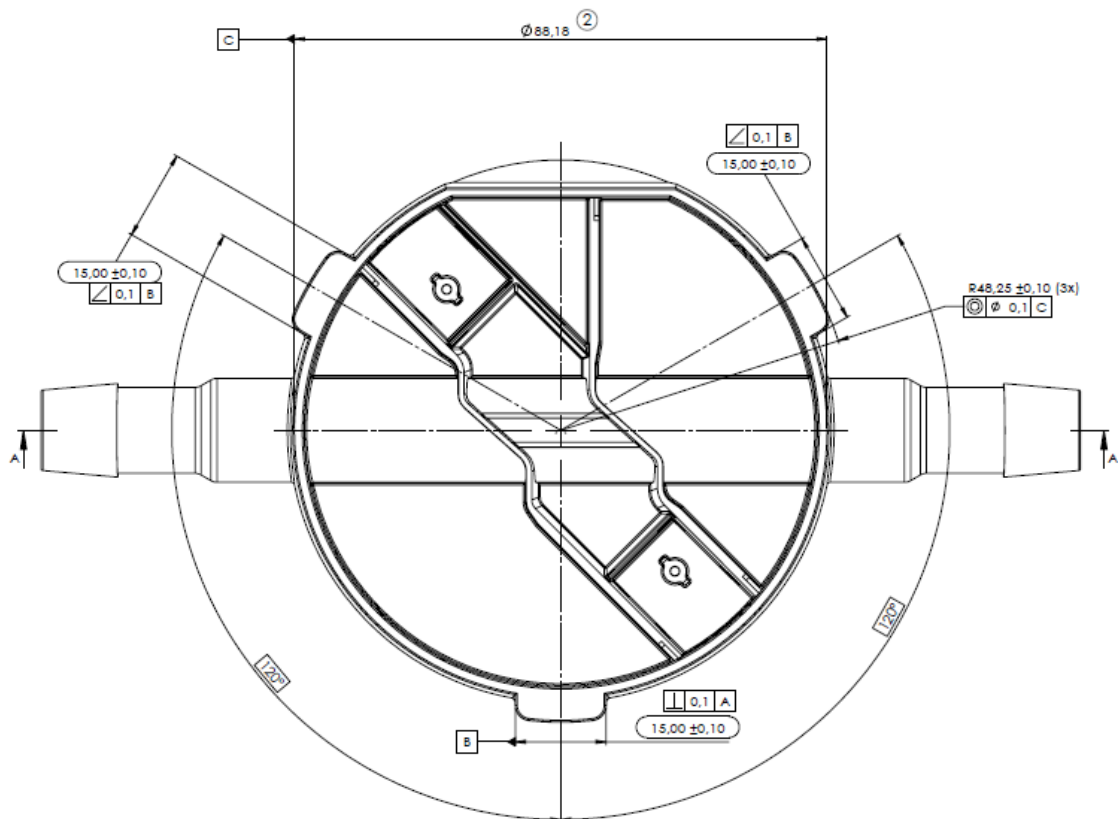

Figure 17: BioProTT™ FlowSU Sensor – Technical Drawing

Ambient Conditions

Air Pressure	70 kPa to 106 kPa
Operating Altitude	up to 2000 m (6600 feet)
Operating temperature range	10 °C to 40 °C (50 °F to 104 ° F)
Storage temperature range	-20 °C to 45 °C (-4 °F to 113 ° F)
Transport temperature range	-20 °C to 55 °C (-4 °F to 131 ° F)
Relative Humidity	10 % to 96 % (non-condensing)
during Transport, Storage, and Operation	

Range of BioProTT™ FlowSU Sensors and their Measurement Range

ID	Size	Qmin [l/min] ²	Qmid [l/min]	Qmax [l/min] ²	Maximal burst pressure [bar] ¹
13713	1/4"	0.1	1	8	5.1
13731	3/8"	0.1	1.25	15	5.1
13714	1/2"	0.1	1.5	20	5.1
13715	3/4"	2.5	4	50	5.1
13716	1"	2.5	6	80	5.1

¹ In combination with appropriate tubes.

² adjusted flow range

19.3 Accuracy of the BioProTT™ FlowSU System

Size	maximum deviation [ml/min] at flow rates between Qmin and Qmid	accuracy between Qmid and Qmax
1/4"	±20	±2%
3/8"	±25	±2%
1/2"	±30	±2%
3/4"	±80	±2%
1"	±120	±2%

Please note: The specified accuracies were determined under the following conditions:

- Medium: distilled water with sodium chloride (salinity between 0.8 ppt and 1.4 ppt)
- Straight In- and Outlet Section: 15 x inner diameter (ID) of sensor
- Fully developed flow profile

Please also note:

- The accuracy is specified within the defined flow measurement range. The flow measurement range is limited by the Qmin and the Qmax.
- Qmin refers to the minimum flow value for which the accuracy is specified.
- Qmax refers to the maximum flow value for which the accuracy is specified.
- The given values describe the positive flow range, but are the same for negative flow values (i.e. if the flow is going against the flow direction indicated on the sensor, flow values are displayed as negative).
- The installation position of the BioProTT™ FlowSU System in regard to the positioning of pumps and valves within the circuit impact the measurement and must be taken into account when it comes to the accuracy of the BioProTT™ FlowSU System.

Annex: Qualification Handbook

BioProTT™ FlowSU Software Overview

With continuous enhancements and improvements of the BioProTT™ FlowSU System portfolio, new software versions are going to be introduced. To ensure optimal performance of the system, please update the system and use the latest software where applicable.

The BioProTT™ FlowSU System runs on the BioProTT™ FlowSU parameter set files (= EEPROM file) and the System Software (= FlowSU Software) of which both should use the latest version.

BioProTT™ FlowSU Parameter Set File

The BioProTT™ FlowSU parameter set file describes and saves all parameters related to the settings of the BioProTT™ FlowSU Sensors.

The currently installed software can be accessed and retrieved on the web interface of the BioProTT™ FlowSU System and is shown under “Cal. Version” on the sensor information page.

Release Date	Change Details	Cal. version	Update Must/ Should
June 13, 2023	Initial software for the BioProTT™ FlowSU System <ul style="list-style-type: none"> - Compatible sensor size: 1/2" - Update file: FlowSU_EEPROM_V1_0_2_0.emt 	V01.00.02.00	Must
November 10, 2023	<ul style="list-style-type: none"> - Addition of sensor sizes 1/4" and 3/4" 	V02.00.00.00	Should
May 24, 2024	<ul style="list-style-type: none"> - Update of calibration parameters for 1/2" and 1/4" sensors to include factory settings - Addition of sensor sizes 3/8" and 1" sensors - Update of calibration parameters for 1/4" and 3/8" sensors 	V02.02.01.00	Should

BioProTT™ FlowSU System Related Software

The currently installed software can be accessed and retrieved on the main page of the web interface of the BioProTT™ FlowSU System.

Rev.	Date	Change Details	Released Software	Update Must/ Should
1.0.0.0	June 13, 2023	Initial software for the BioProTT™ FlowSU System <ul style="list-style-type: none"> - Update file: FlowSU_UpdatePackage_SX01.00.00.00 	V01.00.00.00	Must
1.1.1.0	November 10, 2023	Addition in Web Interface: <ul style="list-style-type: none"> - On-Site Adjustment - Bubble Size Threshold - Selection of Flow Averaging Rate Output of additional information via Modbus-TCP	V01.01.01.00	Must
2.0.2.0	November 22, 2024	EEPROM file is now located on the setup page of the web interface instead of the on-site adjustment area.	V02.00.02.00	Must
2.0.3.0	December 9, 2024	Bug Fixing	V02.00.03.00	Must
2.0.4.0	May 23, 2025	<ul style="list-style-type: none"> • Bug Fixing • Addition of Totalizer Function 	V02.00.04.00	Must

Additional Technical Drawings

BioProTT™ FlowSU System (Article Number 13712.A):

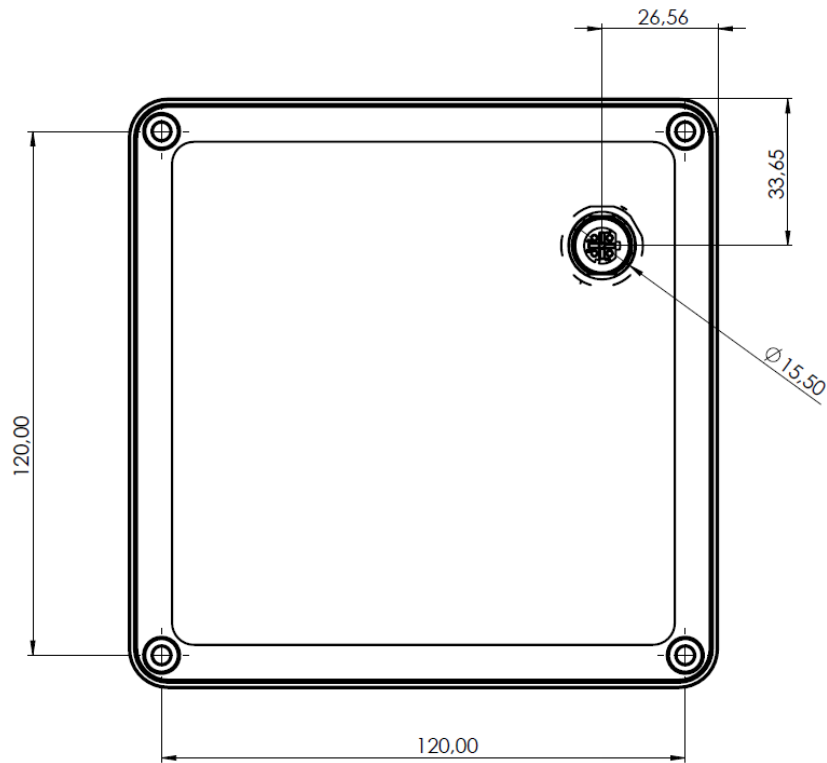

Back View

BioProTT™ FlowSU Sensor SU 1/4-HB-HB (Article Number 13713):

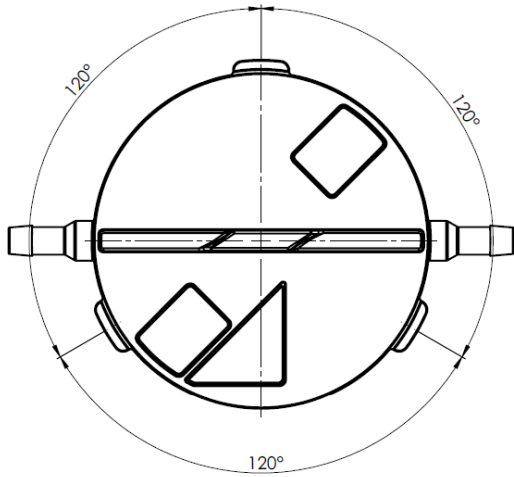

Front

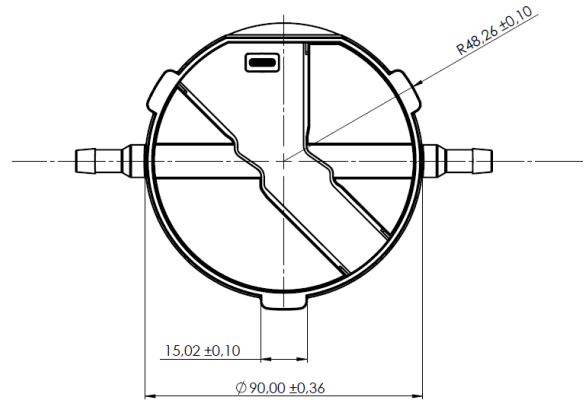

Back

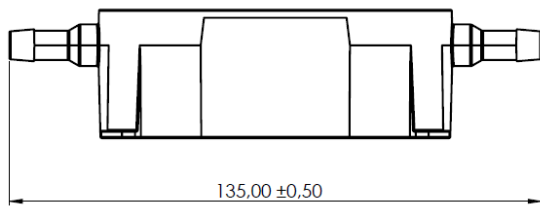

Bottom

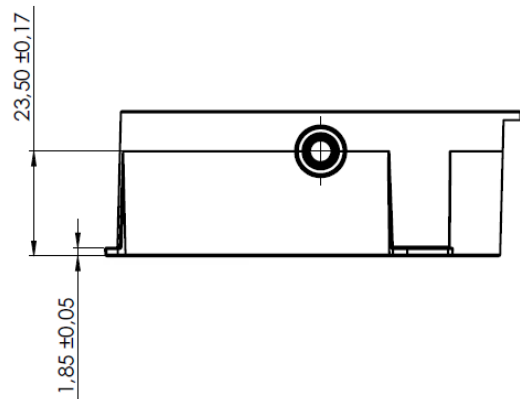

Left Side

BioProTT™ FlowSU Sensor SU 3/8-HB-HB (Article Number 13731):

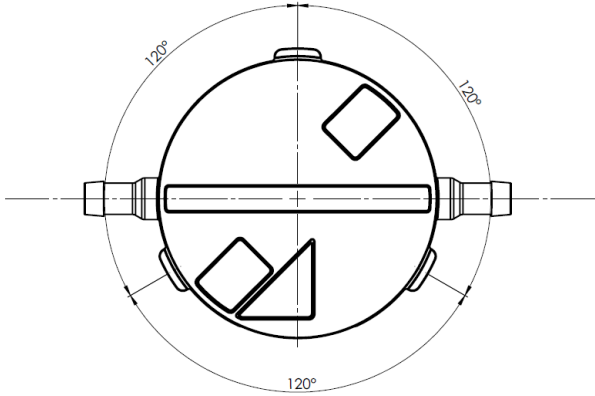

Front

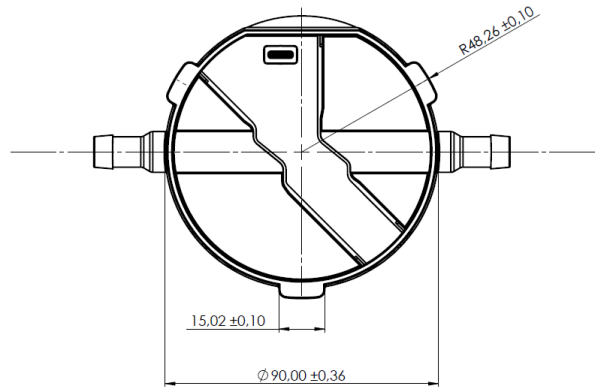

Back

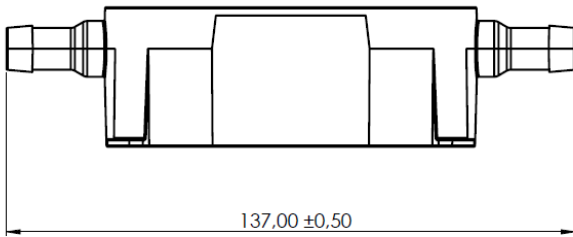

Bottom

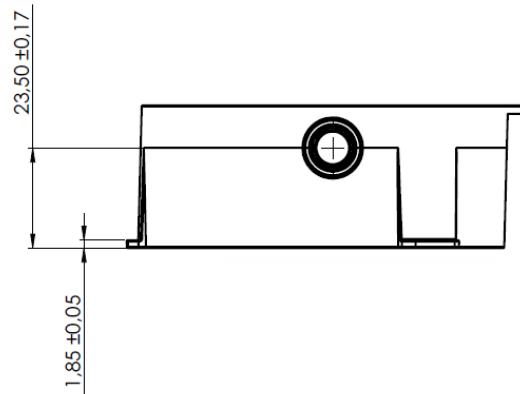

Left Side

BioProTT™ FlowSU Sensor SU 1/2-HB-HB (Article Number 13714):

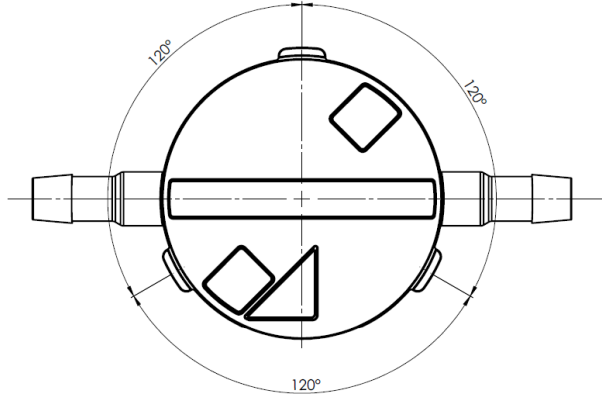

Front

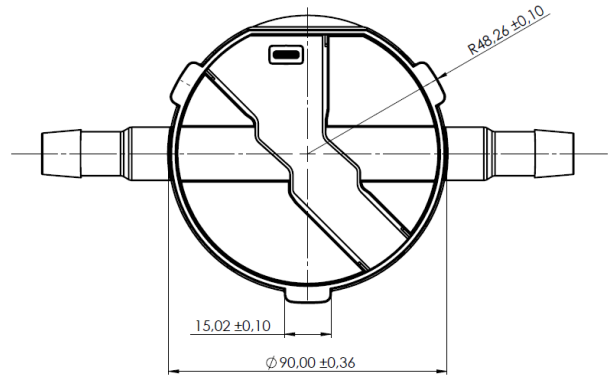

Back

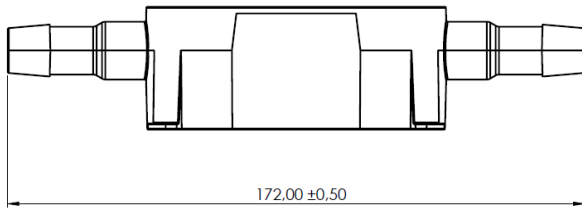

Bottom

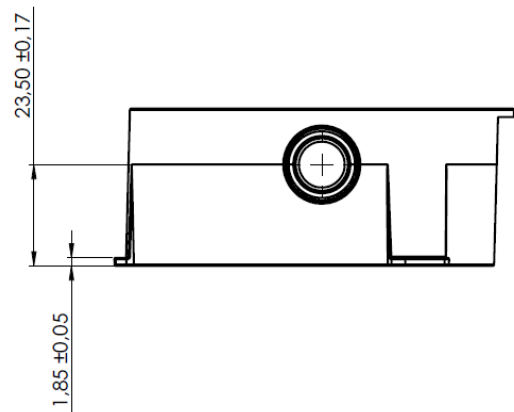

Left Side

BioProTT™ FlowSU Sensor SU 3/4-HB-HB (Article Number 13715):

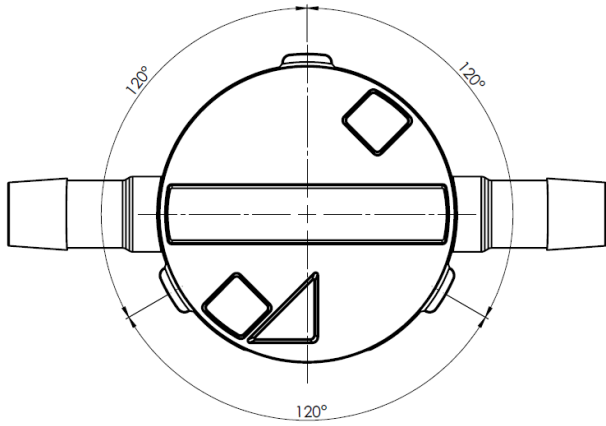

Front

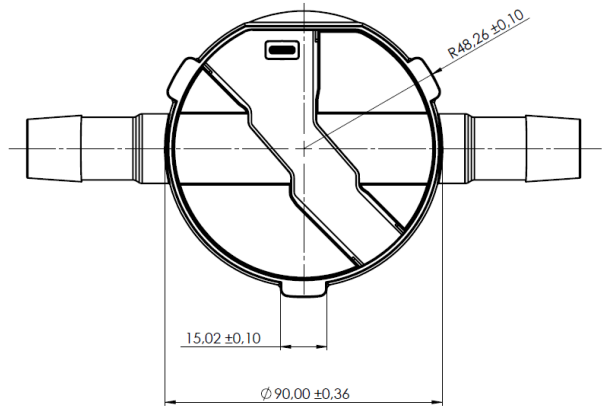

Back

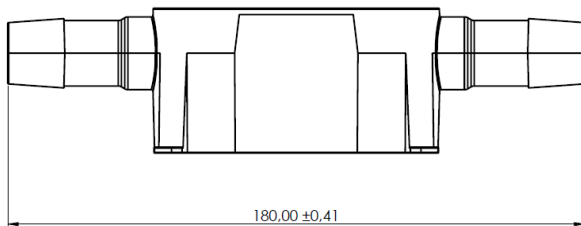

Bottom

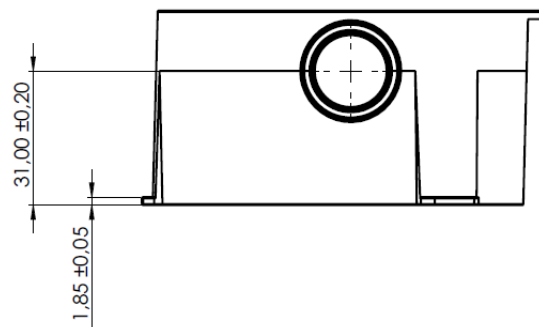

Left Side

BioProTT™ FlowSU Sensor SU 1/1-HB-HB (Article Number 13716):

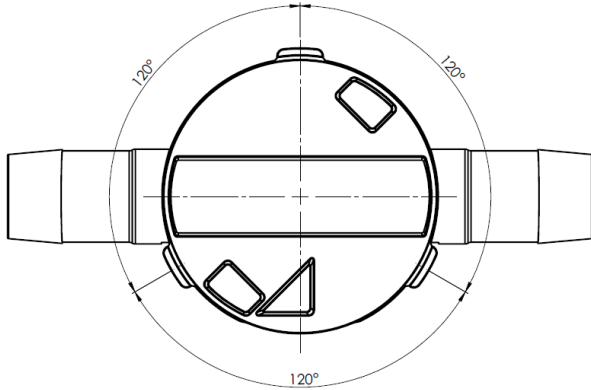

Front

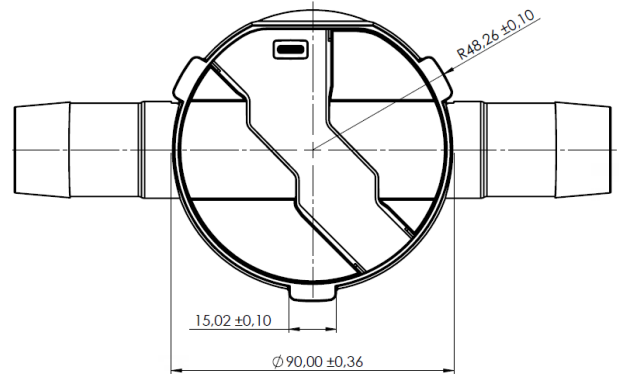

Back

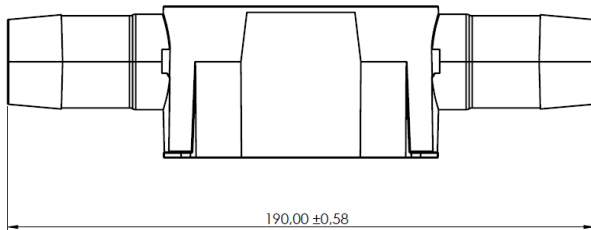

Bottom

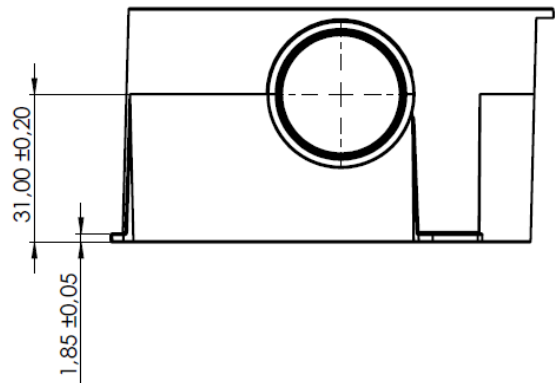

Left Side



ZERTIFIKAT ◆ CERTIFICATE ◆ 認證證書 ◆ CERTIFICADO ◆ CERTIFICAT



Product Service

Certificate

No. Q5 023971 0035 Rev. 03

Holder of Certificate: em-tec GmbH
Lerchenberg 20
86923 Finning
GERMANY

Certification Mark:



Scope of Certificate: Design and Development, Production, Distribution and Servicing of Modules for Heart-Lung Machines/ Assist Systems and Dialysis Machines, Level Sensors for Reservoirs, Ultrasonic Flowmeter and Probes for Volumetric Measurement of Liquids flowing through Vessels, Tubes or Grafts.
Contract Development for Medical Devices

The Certification Body of TÜV SÜD Product Service GmbH certifies that the company mentioned above has established and is maintaining a quality management system, which meets the requirements of the listed standard(s). All applicable requirements of the testing and certification regulation of TÜV SÜD Group have to be complied with. For details and certificate validity see: www.tuvsud.com/ps-cert?q=cert:Q5 023971 0035 Rev. 03

Report No.: 713256866

Valid from: 2023-02-01
Valid until: 2026-01-31

Date, 2023-01-26

Christoph Dicks
Head of Certification/Notified Body



ZERTIFIKAT ◆ CERTIFICATE ◆ 認證書 ◆ CERTIFICADO ◆ CERTIFICAT



Product Service

Certificate

No. Q5 023971 0035 Rev. 03

Applied Standard(s): EN ISO 13485:2016
 Medical devices - Quality management systems - Requirements for regulatory purposes (ISO 13485:2016)
 DIN EN ISO 13485:2016

Facility(ies): **em-tec GmbH**
Lerchenberg 20, 86923 Finning, GERMANY

Design and Development, Production, Distribution and Servicing of Modules for Heart-Lung Machines/ Assist Systems and Dialysis Machines, Level Sensors for Reservoirs, Ultrasonic Flow-meter and Probes for Volumetric Measurement of Liquids flowing through Vessels, Tubes or Grafts.
 Contract Development for Medical Devices

em-tec GmbH
Am Graben 6-8, 86923 Finning, GERMANY

Design and Development, Production, Distribution and Servicing of Modules for Heart-Lung Machines/ Assist Systems and Dialysis Machines, Level Sensors for Reservoirs, Ultrasonic Flow-meter and Probes for Volumetric Measurement of Liquids flowing through Vessels, Tubes or Grafts.
 Contract Development for Medical Devices

Parameters: n/a

CE-Declaration



Declaration of Conformity

em-tec

Date of Declaration 2023-11-03
 Trade Name BioProTT™ Flow SU System
 Objects of Declaration 1. BioProTT™ FlowSU System
 2. BioProTT™ FlowSU Sensor (all sizes)
 Legal Manufacturer em-tec GmbH
 Address Lerchenberg 20
 D-86923 Finning
 Germany

We herewith declare that the objects of declaration described above meet the provisions of the following EU directives and regulations:

- EU Directive 2012/19/EU** Waste electrical and electronic equipment (WEEE)
- EU Directive 2011/65/EU** Restriction of the use of certain hazardous substances in electrical and electronic equipment (RoHS)
- EC Directive 2014/30/EU** Harmonisation of the laws of the Member States relating to electromagnetic compatibility (recast)

The manufacturer is exclusively responsible for the declaration of conformity.
 All supporting documentation is retained under the premises of the manufacturer.

Place, Date of Issue: Finning, 2023-11-03

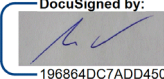
03.11.2023 
 Date, Signature
 Markus Ewen
 Person responsible for regulatory compliance (PRRC)

em-tec GmbH
 Lerchenberg 20
 D-86923 Finning
 Tel.: 08806/9236-0
 Company Stamp

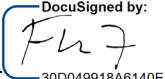
03.11.2023 
 Date, Signature
 Fredrik Jönsson
 Managing Director

CB Test Report

	<p>Ref. Certif. No.</p> <p>BE-44781</p>
<p>IEC SYSTEM FOR MUTUAL RECOGNITION OF TEST CERTIFICATES FOR ELECTRICAL EQUIPMENT (IECEE) CB SCHEME</p>	
<p>CB TEST CERTIFICATE</p>	
<p>Product</p>	<p>Flow Measurement System</p>
<p>Name and address of the applicant</p>	<p>em-tec GmbH Lerchenberg 20, 86923, Finning, Germany</p>
<p>Name and address of the manufacturer</p>	<p>em-tec GmbH Lerchenberg 20, 86923, Finning, Germany</p>
<p>Name and address of the factory</p>	<p>em-tec GmbH Am Graben 6-8, 86923, Finning, Germany <input type="checkbox"/> Additional Information on page 2</p>
<p><i>Note: When more than one factory, please report on page 2</i></p>	
<p>Ratings and principal characteristics</p>	<p>Powered via PoE (802.3af-2003)</p>
<p>Trademark (if any)</p>	<p>BioProTT™</p>
<p>Customer's Testing Facility (CTF) Stage used</p>	
<p>Model / Type Ref.</p>	<p>BioProTT™ FlowSU System</p>
<p>Additional information (if necessary may also be reported on page 2)</p>	<p>- <input type="checkbox"/> Additional Information on page 2</p>
<p>A sample of the product was tested and found to be in conformity with</p>	<p>IEC 61010-1:2010, IEC 61010-1:2010/AMD1:2016 National Differences: EU Group Differences, CH, JP, CA, US, AU, NZ</p>
<p>As shown in the Test Report Ref. No. which forms part of this Certificate</p>	<p>T4YS0001</p>
<p>This CB Test Certificate is issued by the National Certification Body</p>	
<p>SGS Belgium NV - Division SGS CEBEC Riverside Business Park Bid Internationalelaan 55, Building K B-1070 Brussels, Belgium</p>	
<p>Date: 2023-05-10</p>	 <p>Signature: Carogero Lana</p>

Biocompatibility Declaration

Regulatory Compliance Declaration



Date of Declaration 2024-06-25
 Trade Name BioProTT™ FlowSU System
 Object of Declaration BioProTT™ FlowSU Sensor (all sizes)
 Legal Manufacturer em-tec GmbH
 Address Lerchenberg 20
 D-86923 Finning
 Germany

We herewith declare that the object of declaration described above meet provisions of the following directives and regulations:

USP <61>	Microbiological Examination of Non-Sterile Products: Microbial Enumeration Tests
Ph. Eur., 2.6.12	Microbiological Examination of Non-Sterile Products: Total Viable Aerobic Count
DIN EN ISO 11737-1: 2021	Sterilization of health care products - Microbiological methods - Part 1: Determination of a population of microorganisms on products
USP <85>	Bacterial Endotoxins
Ph. Eur. 2.6.14	
USP <788>	Particulate Matter in Injections
Ph. Eur. 10, 2.9.19	Particulate contamination: sub-visible particles
USP <87>	Biological Reactivity Tests, in vitro
DIN 10993-5	Tests for in vitro cytotoxicity
USP <88>	Biological Reactivity Tests, in vivo
ISO 10993-10	Tests for skin sensitization
ISO 10993-11	Tests for systemic toxicity

The manufacturer is exclusively responsible for the declaration of conformity.

All supporting documentation is retained under the premises of the manufacturer and can be requested by contacting em-tec.

Place, Date of Issue: Finning, 2024-06-25

25.06.2024

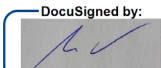
DocuSigned by:

 196864DC7ADD450...

Date, Signature

Markus Ewen

Person responsible for regulatory compliance (PRRC)

DS

 Company Stamp

26.06.2024

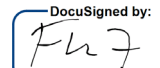
DocuSigned by:

 30D049918A6140E...

Date, Signature

Fredrik Jönsson

Managing Director

IEC and IP Declaration

Regulatory Compliance Declaration



No. of Declaration 2023-11-03
 Trade Name BioProTT™ FlowSU System
 Objects of Declaration 1. BioProTT™ FlowSU System
 2. BioProTT™ FlowSU Sensor (all sizes)

 Legal Manufacturer em-tec GmbH
 Address Lerchenberg 20
 D-86923 Finning
 Germany

We herewith declare that the object of declaration described above meet provisions of the following directives and regulations:

IEC 61010-1:2010; IEC 61010-1:2010 /AMD1:2016	Safety requirements for electrical equipment for measurement, control and laboratory use
IEC 60529: 2013	Degrees of Protection provided by enclosures (IP-Code): Tested and found to be compliant with IP65 class in mated condition or with protection cap
EN 61326-1:2021; IEC 61326-1:2020	Emission Class A CISPR 11 Group 1 Immunity test requirements for equipment intended to be used in a basic electronic cabinet: pass Immunity test requirements for equipment intended to be used in an industrial electromagnetic environment: pass Immunity test requirements for equipment intended to be used in a controlled electromagnetic environment: pass

The manufacturer is exclusively responsible for the declaration of conformity.
 All supporting documentation is retained under the premises of the manufacturer and can be requested by contacting em-tec.

Place, Date of Issue: Finning, 2023-11-03

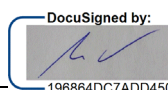
03.11.2023 
 Date, Signature
 Markus Ewen
 Person responsible for regulatory compliance (PRRC)

em-tec GmbH
 Lerchenberg 20
 D-86923 Finning
 Tel.: 08806/9236-0
 Company Stamp

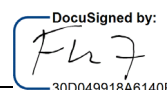
03.11.2023 
 Date, Signature
 Fredrik Jönsson
 Managing Director

Document Change History

Version	Release Date	Changes
V1.0	n.a.	internal version only
V2.0	n.a.	internal version only
V3.0	May 30, 2023	first released manual version
V4.0	November 14, 2023	<ul style="list-style-type: none"> • Addition of Change History • Addition of Modbus-Registers • Adaptation of Calibration Tables • Reference to On-Site Adjustment Guide • Addition of BioProTT™ FlowSU Software Overview • Addition of technical drawing of the BioProTT™ FlowSU Station, the BioProTT™ FlowSU Sensor 1/2-HB-HB, and the BioProTT™ FlowSU Sensor 1/4-HB-HB • Addition of: <ul style="list-style-type: none"> – Lexan Resin HPH4404 Datasheet, – ISO 13485 Certificate, – CE Declaration, CB Test Report, – Biocompatibility Declaration, – IEC and IP Declaration
V5.0	June 27, 2024	<ul style="list-style-type: none"> – New version of parameter set file – Updated Regulatory Compliance Declaration
V6.0	August 13, 2024	<ul style="list-style-type: none"> • article numbers in Additional Technical Drawings corrected • Weight of BioProTT™ FlowSU System corrected (chapter 18.1) • Weight of 1" Sensor corrected (chapter 18.2) • Addition of USP 661 (chapter 18.2) • Addition of ± before each number (chapter 18.3) • Addition of PoE Standard IEEE 802.3af Mode A (chapter 5 and 7.3) • Addition of PoE Pin Assignment (chapter 6.1)
V7.0	November 22, 2024	<ul style="list-style-type: none"> • update of SW version to 02.00.02.00 • specification of PoE injector as "managed" PoE injector throughout document • addition of button "Factory Reset" to Configuration page of web interface (previously part of Flow Sensor Adjustment section) • updated information regarding USP <661> in chapter 'Technical Specifications'
V8.0	December 9, 2024	<ul style="list-style-type: none"> • update of SW version to 02.00.03.00
V9.0	June 11, 2025	<ul style="list-style-type: none"> • further specification of PoE injector as "managed and galvanically isolated" PoE injector throughout document • inclusion of totalizer function

About em-tec GmbH

em-tec has been a specialist for flow measurement systems in the medical and bioprocessing technology sector for over 30 years. The company's core competence is the non-invasive flow measurement using the ultrasonic transit-time method, that is used for applications in extracorporeal circulation systems of life-sustaining systems as well as in biopharma applications that use flexible tubes. Headquartered in Finning, Germany, em-tec is part of PSG®, a Dover company.

For more information about em-tec, please visit psgdover.com/em-tec.

About PSG Biotech

PSG® Biotech is dedicated to Caring For Every Drop in the biopharmaceutical industry by providing a comprehensive portfolio of specialty flow-control solutions. With its ground-breaking innovation, PSG Biotech offers pumps, sensors, and flow meters that have been designed to safely transfer and precisely meter the most delicate biologics, medicines and therapeutics, all while increasing yield, throughput and speed to market.

PSG Biotech is a product brand of PSG®, a Dover company, Oakbrook Terrace, IL, USA, which is comprised of several leading pump and flow-measurement brands, including Abaque®, All-Flo™, Almatec®, Blackmer, Ebsray®, em-tec, Griswold®, Hydro™, Malema, Mouvex®, Neptune®, Quantex™, Quattroflow®, RedScrew™ and Wilden®. You can find more information on PSG Biotech at psgdover.com/biotech and on PSG at psgdover.com.



BIOTECH